



جامعة أم القرى – كلية التربية

# إدارة المعرفة وإمكانية تطبيقها في الجامعات السعودية

## دراسة تطبيقية على جامعة أم القرى

**إعداد**

ياسر بن عبد الله بن تركي العتيبي

:

**إشراف**

د/ رمضان أحمد عيد الصباغ

-

( )

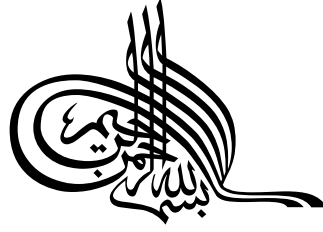

قرآن کی :

وَقُلِ الْحَمْدُ لِلَّهِ سِيرِكُمْ ءَايَاتِهِ ۚ فَتَعْرِفُونَهَا وَمَا رَبُّكَ بِغَافِلٍ عَمَّا  
تَعْمَلُونَ ﴿٩٣﴾

# ملخص الدراسة

اسم الباحث:

عنوان الدراسة:

"

"

أهم أهداف الدراسة:

- 
- 
- 
- 
- 

الإطار النظري للدراسة:

):

منهج الدراسة:

( )

-T- Test

أهم نتائج الدراسة

- (
- (
- (
- (

أهم التوصيات:

- (
- (
- (
- (
- (



## إهداء

- إلى أبوي الكريمين ...  
... أمد الله في عمرهما ، وجزاها عني خير الجزاء.
- إلى إخوتي الأعزاء ..... الذين كانوا لي بعد الله خير معين .
- إلى أخواتي العزيزات ..... اللاهجات بالدعاء.
- إلى زوجتي ..... رمز التضحية والوفاء.
- إلى بناتي ..... نبض قلبي ..... وقرّة عيني ...
- إلى روح أستاذي الدكتور ... سائلاً المولى عز وجل أن يرحمه رحمة الأبرار، وأن يسكنه فسيح جناته.

إليهم جميعاً أهدي ثمرة جهدي

الباحث

## شكر وتقدير

.

.

.

:

.

.

.

:

.

البحاا

## فهرس المحتويات

	الموضوع
	• .
	• ( ) .
	• ( ) .
	• .
	• .
	• .
	• .
	• .
	• .
	• .
	<b>الفصل الأول: الإطار العام للدراسة</b>
	• .
	• .
	• .
	• .
	• .
	• .
	• .
	• .
	<b>الأطر النظرية للدراسة</b>
	<b>الفصل الثاني: إدارة المعرفة وعملياتها</b>
	• .
	• .
	• .
	<b>الفصل الثالث: إدارة المعرفة والجامعات المعاصرة</b>
	• .
	• .
	• .



	الموضوع
	<b>الفصل الرابع : إجراءات الدراسة الميدانية</b>
	•
	•
	•
	•
	•
	<b>الفصل الخامس: عرض نتائج الدراسة وتفسيرها</b>
	•
	•
	<b>الفصل السادس: التصور المقترح لإدارة المعرفة</b>
	•
	•
	<b>قائمة المراجع</b>
	<b>الملاحق</b>



## فهرس الجداول

	( L.S.D )	
		LSD
	( ) ( )	
	( ) ( )	
	( ) ( )	
	( ) ( )	
	( ) ( )	
	( ) ( )	
	( ) ( )	
	( ) ( )	(
	( ) ( )	(

## فهرس الأشكال

	<b>Beckman Liebowits</b>	
	<b>Marquardt</b>	
	<b>Wiig</b>	
	<b>Winosky</b>	
-		
	[       ]       [       ]	
	[       ]       [       ]	
	[       ]       [       ]	
	[       ]	
	[       ]       [       ]	
	[       ]       [       ]	
	[       ]       [       ]	
	[       ]       [       ]	
	[       ]	
	[       ]	
	.	

# الفصل الأول

## الإطار العام للدراسة

- مقدمة .
- مشكلة الدراسة وأسئلتها.
- أسئلة الدراسة .
- أهمية الدراسة
- أهداف الدراسة
- حدود الدراسة
- مصطلحات الدراسة
- الدراسات السابقة.

# الفصل الأول

## الإطار العام للدراسة

### مقدمة

( )

...

.( Thornburg, 1997.P.11 ) .

.

.

.( ) .

( )

.

.

.( ) .

.

...

.

.

( )

## مشكلة الدراسة وأسئلتها

.( ) .

:

)..

(

) (

) (

) (

Janzon) (

Kang)

.(

Calbarge & lambarge

.(

Nguyen)

.

:

(

) ...

( )



( Foster & Billy, 1999. p:34 ) .

.(Fedeline, 1998. p:57 )

/ / )

(

.

:

:

(

(

(

(

(

:

.

(

(

( )

## أهمية الدراسة

.

.

( ) ( )

.

( ) **Fedeline**

:

.

:

-

( )

.

( )

- :

( )

## أهداف الدراسة

(

(

(

(

:

•

•

•

•

(( ))

(

( )

## حدود الدراسة

- الحدود الموضوعية :

- الحدود المكانية :

- الحد الزمني :

./ /

## مصطلحات الدراسة

المعرفة : Knowledge

( )

.( )

: ( )

.( )

" ( )

" "

."

( )

( )

## إدارة المعرفة : Knowledge Management

( ) . <http://www.alnoor->

( word.com

( 1999 Verespej )

Horder & Fearnley )

(

.  
:

.  
**تنظيم المعرفة :**

.  
**توليد المعرفة :**

.  
**التشارك في المعرفة :**

## الدراسات السابقة

( )

:

.

\*

.

\*

:

## المحور الأول الدراسات العربية :

: ( )

:

.

:

"

"

-

.

.

-

.

-

-

.

"

"

-

.

( )

"

"

.

: ( )

:

.

( )

:

.

-

.

-

.

-

.

-

.

-

**( Benchmarking )**

.

( )

·  
:

( )

·  
:

( )

·  
:

**المحور الثاني الدراسات الأجنبية :**

·  
:

**Collins, Hage, Hull & Teachman (1993)**  
( )

**The Impact of Knowledge on the Survival of American  
Manufacturing Plants**

·  
:

:

( )



) **Death**

(

: **. Event – history Analysis**

( ) ( ) -

-

:

. ( ) **Death** ( )

-

: **(2001) Connelly & Kellway**

**Predictors of Employees' Perceptions of Knowledge Sharing Cultures**

)

( **Tenure**

( )



: Politis ( 2001 )

**The Relationship of Various Leadership Styles to Knowledge Management**

:

**Transformational**  
:  
**Transactional**

**Sims & Manz**

**Bass Multifactor Leadership**

**Stogdall**

**. Leadership Behavior Description Questionnaire**

**Politis**

:

**Participative & Self-**

**Management Leadership**

-

-

-

-

Acquisition

Knowledge-

. Enabled Leader

: Chaudhry & Higgins ( 2001 )

knowledge management teaching

.( )

(% ) (% ) -  
(% ) (% )

( )

- ) -  
- - -  
- .( -

( : ) : **Morris ( 2001 )**

**Knowledge Management : Opportunity for list graduates**

:  
.  
:  
) -  
- - - -  
- .( -  
- - - ) -  
- .( - -  
- ) -  
- .( - - - -  
- - ) -  
- .(

·  
:  
( 2002 ) Chan & Ford

· :  
:

**Knowledge Sharing in A Cross-Cultural Setting : A Case Study**

:

**Cross-Cultural Differences**

·  
**Subsidiary**

·  
:  
-

·  
:  
-

·  
:  
-

·  
:  
-

·  
:  
-

: (2002) Kylberg & Lundberg  
(Tetra Pak :

Improving Knowledge Transfer : A Study of An Innovation Project at  
Tetra Pak

Tetra Pak

/

: ( 2002 ) Carolyn

**Validating A unified framework for knowledge management**

:

.

:

.

.

-

-

.

-

.

-

.

.

:

**( 2002 ) Holowetzki**

:

**The Relationship Between Knowledge Management and  
Organizational Culture : an Examination of Cultural Factors that Support  
the Flow and Management of Knowledge Within an Organization**

:

.

**Oregon**

-

:

.

( )



)

.(

-  
-  
-  
-

( 2003 ) Kang

**The Knowledge Advantage : Tracing and Testing the Impact of Knowledge Characteristic and Relationship on Project Performance**

( )

:

:

( 2003 ) Janzon

**Management of Knowledge in Innovation : A Case Study of SKF Nova**

:

**SKF Nova**

:

**SKF Nova**

-

: **SKF**

-

.

.

-

/

-

.

**SKF**

.

:

:

( 2004 ) Smith

**The Socialization of Knowledge : A Systems View of Knowledge Management in Large , Complex , Highly Technical , Global Organizations**

:

.

-

.

-

.

-

.

.

## ملخص الدراسات السابقة

.

:

○

.

○

.

○

.

○

.

○

.

○

.

:

○

.

○

.

○

.

○

.

.

## الفصل الثاني

### إدارة المعرفة وعملياتها

#### أولاً : المعرفة

- مفهوم المعرفة وأهميتها
- الهرم المعرفي
- أبعاد المعرفة وخصائصها
- أنواع المعرفة

#### ثانياً : إدارة المعرفة

- المفهوم والأهمية
- مجالات إدارة المعرفة
- مداخل إدارة المعرفة
- استراتيجيات إدارة المعرفة
- نماذج إدارة المعرفة

#### ثالثاً : عمليات إدارة المعرفة

- تنظيم المعرفة
- توليد المعرفة
- التشارك في المعرفة

## الفصل الثاني

### إدارة المعرفة وعملياتها

#### تمهيد

:

:

#### أولاً : المعرفة

#### 1- مفهوم المعرفة وأهميتها

( )

. ( )

}: .

. ( : ) {

( )

: ) { } : . (

: ( )

. ( )

( ) **Barnes** )

. **Know-How** ( )

" ( )

" ."

."

( )

": ( )

."

( )

.

" ( )

"

.

( )

## Innovation

٣- الهرم المعرفي



( ) Stettner : (

.

.

**Warner & Norgan**

: ( )  
( - )

. **Know-How**

.

( ) **Wiig** : (

:

:( ) •

.

: •

.

: •

.

.

: •

.

.

: ( ) **Fireston**

: •

.

( )

& Prusak

. **Conflictual**

: ( ) Davenport

. ( )

: **Comparison** •

: **Consequences** •

: **Connections** •

: **Conversation** •

( )	:	(
<b>Signals</b>		
<b>Knowledge</b>	<b>Information</b>	<b>Data</b>
		<b>Wisdon</b>

( )

( )

: Kakes

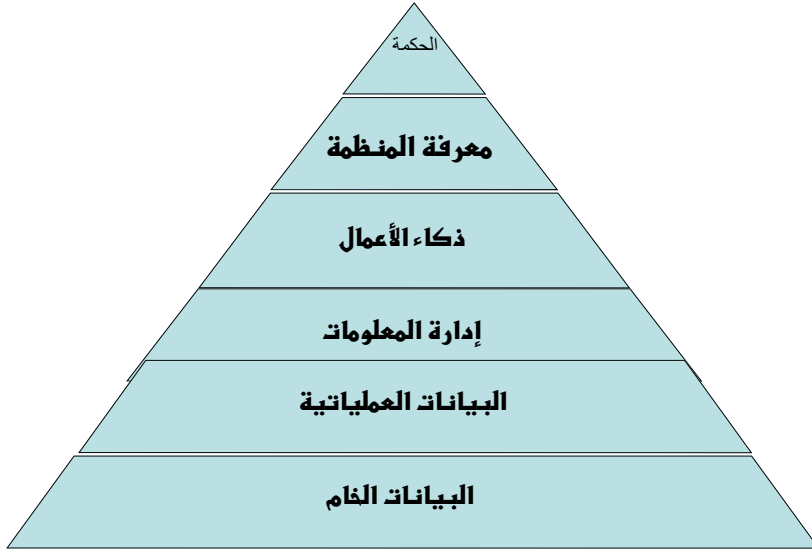

( )

المصدر Kakes , Elayna , ed. ( 2003 ) Knowledge Management : Current Issue & Challenges , U.S.A. , Idea Group Publishing , p.74

: ( )

( Wise )

Operational

Atomic Detail "

"

( )

Business Intelligence "

"

( )

( )

**Insights**

**Timeless**

**Marquardt , ) Beckman Liebowits ( 2000**

:

**Beckman Liebowits ( )**

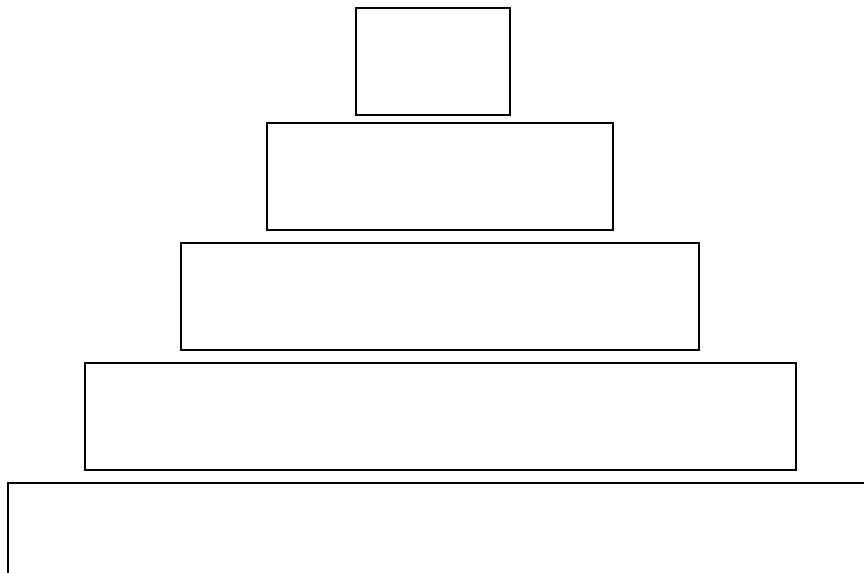

**Marquardt , Michael J. ( 2002 ) Building The Learning Organization , U.S.A., Davis – Black Publishing Company , p.23**

**( ) : ( )**  
**)**

**.(**

**( )**

**( )**

٣- أبعاد المعرفة وخصائصها

= : + +

( )

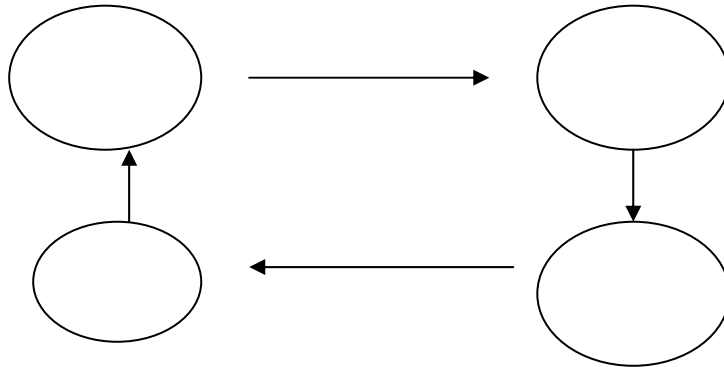

( )

( )

( - )

:( )

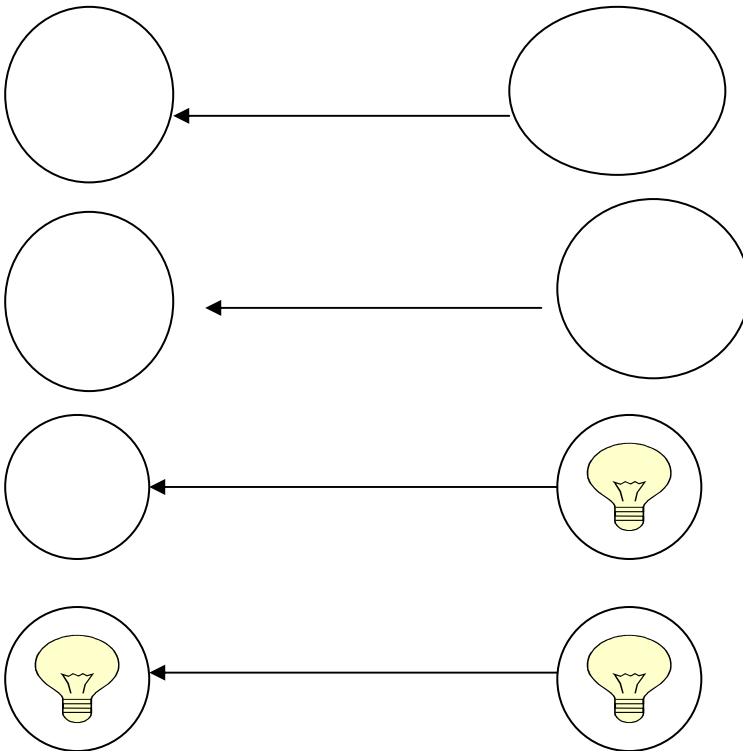

( )

( )

.

( - ) **Housel & Bell**

:

:

•

.

:

•

.

:

•

.

( **Immanent K.** )

:

•

.

∴

•

.

:

•

( **Process K.** )

.

( - - )

( )

( - ) Sveiby

:

: Tacit •

: Action – Oriented •

Sensory

: Supported By Rules •

: Constantly Changing •

. Static

(Housel & Bell) (Sveiby)

( )

٤- أنواع المعرفة

( )



( )

:

: -

.

: -

. **insight**

: -

. **introspection**

.

: ( )

**Conceptual Knowledge** (

:

)

. (

**Contextual Knowledge** (

( )

( )

( )

**Procedural Knowledge**

)

(

(

)

)

.(

( -

) **Balogun & Hailey**

:

:

**Tacit Knowledge**

)

(

( )

( ) **Cullen**

( )

( ) Nonaka & Takeuchi

. Intuition

Hunch

values

Ideals

: ( ) Wiig

( )

( ) Coakes

: Cognitive

( )

) Nonaka & Takeuchi

(

. Know-How

Crafts

( )

( ) Wiig

Internalized



Explicit Knowledge

(



( ) Nonaka & Takeuchi

( )

( )

( ) Wiig

( )

:

- 
- 
- 
- 

" " " " " "

:

"

-( )

•

( )

-( )

•

-( )

•

( )

- ( ) •

- ( ) •

- ( ) •

:

• •

• •

• •

•

•

:

:

: (

•

•

( )



## ثانياً: إدارة المعرفة

### 1- المفهوم والأهمية

( - )

:

•

•

•

:

( - ) Wiig

"

( )

Explicit Systematic

"

" ( )

( )



[ - - - - ]

( ) Horder & Fearnley

) Capshaw & Frappaol

( -

( Zerega ) Dorothy Yu

( Little et al) Cross

Frappaolo & Capshaw

( )

" ( )

"

( )

( ) Gartner Group

( ) Griffiths

[ - - ]

( )

"

."

( )

( ) (pages of data)

( , )

( , )

( )

"

:( )

-

)

( **cummings & Worley**

-

.

-

( **Knowledge-Bases**)

**DSS**

**MIS**

**GDSS**

.( **wig** )

-

.

-

**Digitized**

**Multimedia**

( )

Synergy Management -

Synergy

Cmmings

)

(

& Worley

)

(

:

-

..

( )

٠  
٠  
**٣- مجالات إدارة المعرفة**

: ( )  
:

:

:

:

**Ceatl** )

:( -

: (

٠  
( )

: (

.

: (

.

: (

).

.( - **Hailey**

( ) **Morris**

( : (

( ( ( ( ( ( (

.

( (

) **Devenport**

: (

: -

.

- 
- 
- 
- 
- 

.

.

.

.

-

.

-

.

-

.

( )

٣- مداخل إدارة المعرفة

Wiig ( ) :

Knowledge Transfer Mode Perspective •

Knowledge Assets Building Perspective •

Knowledge Assets Management Perspective •

**Intelligent – acting Operation Perspective**

•

.

**Reengineering Perspective**

•

.

**Total Quality Perspective**

•

.

**Knowledge Culture Perspective**

•

.

( - - )

.

( - )

:

:

•

.

( )



: •

.

:( ) •

.( ) :

:( **Leverage Approach** ) •

.

:( **Innovative Approach** ) •

.

: •

.

:

.

▪

.

▪

▪

▪

▪

.

( )

- ) : . (

:  
( Information School ) :

( System Expert )

Logie )

( Neural Networks)

. ( Fuzzy

:

( Expert System ) -

Engineer )

( Knowledge

( Knowledge – Base )

Interface )

( Working Memory)

Domain )

( Engi Knowledge )

( Engine

Barnes ) ( End – user )

( Expert

. ( -

( )

:  
(Declarative Knowledge)  
(Meta Knowledge)

(Procedura Knowledge)

(Neural Networks)

-

( - ) .

( )

.

.

.

:

...

.( ) .

.

( )

( Behavioral School ) :

( Team Work)

( Virtual Team Work)

.( )

).

.( **Wiig**

.( **Cullen** ).

.

.

( )

## ٤- استراتيجيات إدارة المعرفة

-

-

. ( )

( - ) Wiig

:

**Grow Slowly**

•

**Strategy**

**Cautious Deliberation Strategy**

•

**Support of Advanced**

•

**and Proactive Perspectives Strategy**

( )

.

":

.( )

.

( - ) **Morten**

. :

[ **Codification Strategy** ] : •

.( - ).

.

[ **Personalization Strategy** ] : •

( **K.Network** )

( )

( - ) .

## ٥- نماذج إدارة المعرفة

:

( ) Marquardt (

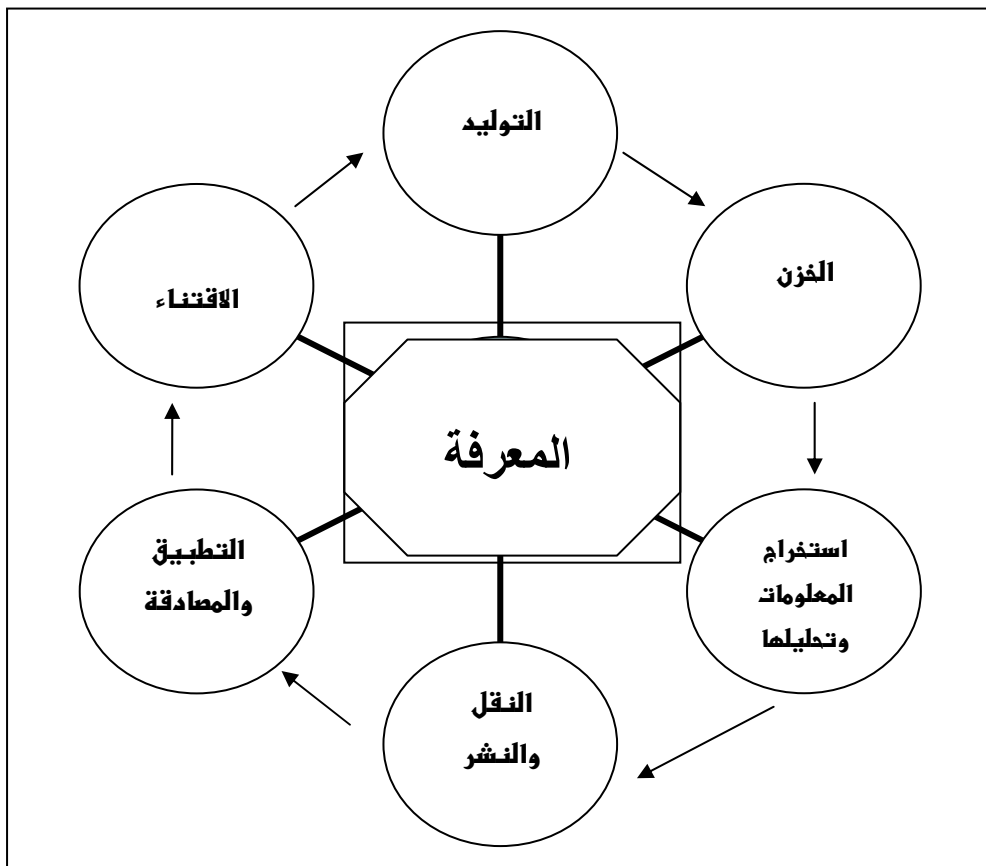

Marquardt , Michael J . ( 2002 ) Building the Learning Organization , U.S.,A. , Davis – Black publishing Company, p. 27

( )

( )

:

**Acquisition** •

**Creation** •

**Storage** •

**Analysis and Data Mining** •

**Transfer and Dissemination** •

**Application and Validation** •

( )



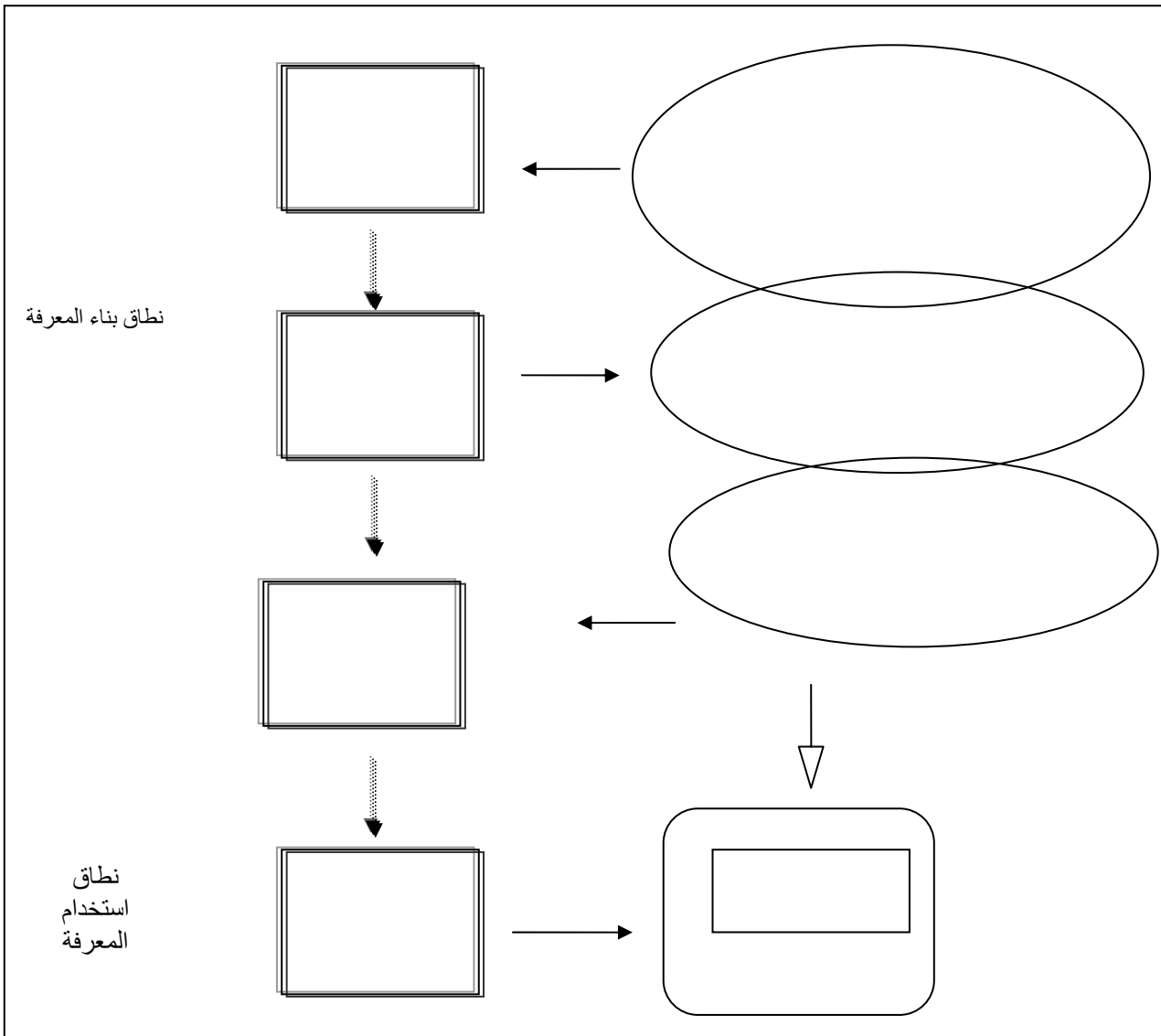

Wiig , Karl M . ( 1993 ) Knowledge Management Foundations : Thinking about Thinking How People and Organizations Create , Represent , and Use knowledge , U.S.A. , Schema Press, 53

: Wiig

:

( ) **Barton** (

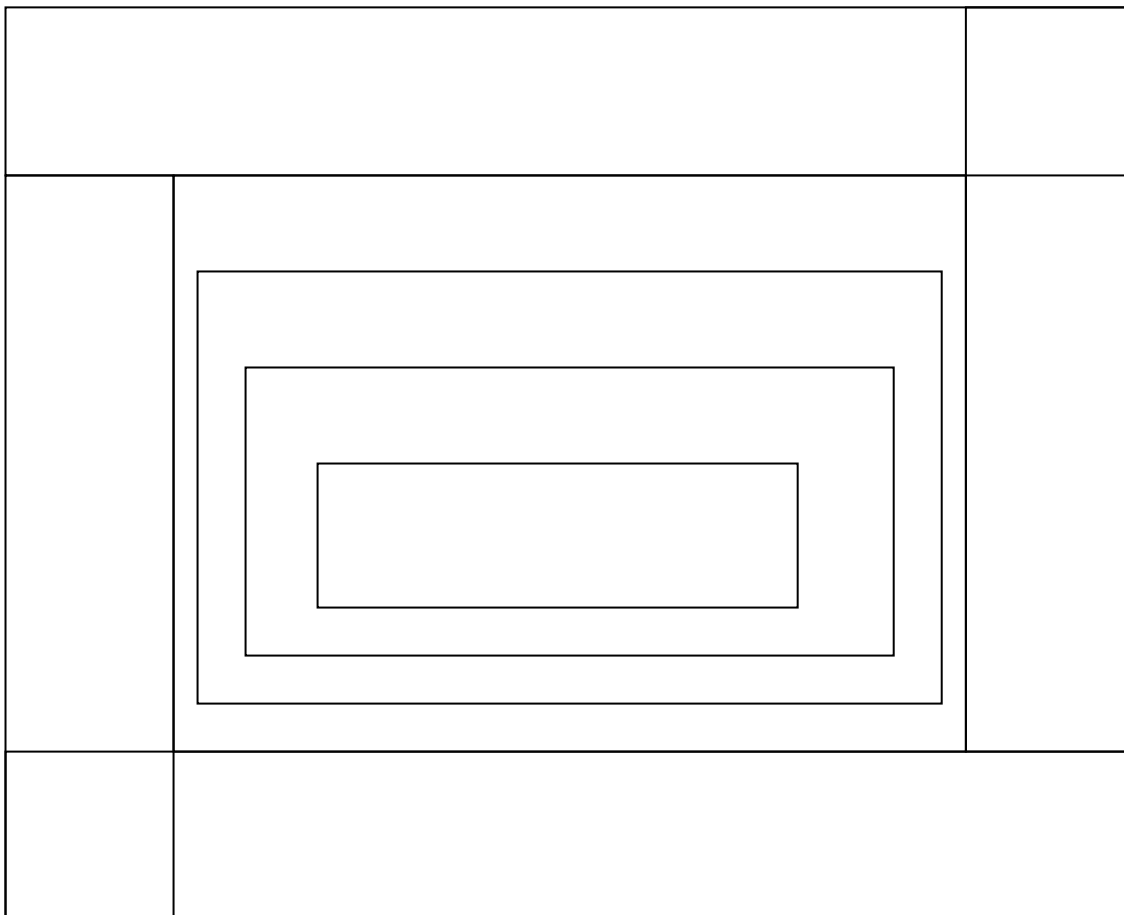

**D.Leonard – Barton : Core Capabilities and Core Rigidities : a Paradox in Managing New Product Development , Strategic Management Journal , No. ( 13 ) , pp 111 – 125 .**

( )

Core )

: - - .( Capability

Little Values

( )

( ) Winosky (

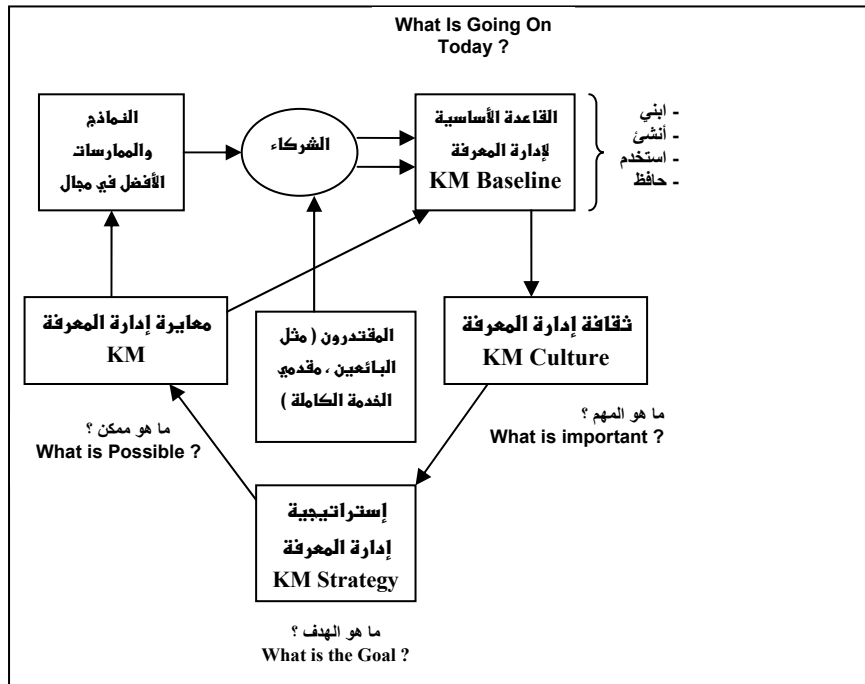

Denmis E.Winosky : KM ( 2001 ) : Approaches and Methodologies

in : Roman C.Barquien et al ( Ed ) : Building Knowledge Management Environment For Electronic Government Concepts , Virginia , pp 16

( )

·  
:( ) ) ·  
·

·  
:( ) ) ·  
·  
·  
:( ) ) ·

·  
:( ) ) ·

·  
[ - - - ]

·  
·  
·  
·  
·  
·  
·  
·

( )

ثالثاً : عمليات إدارة المعرفة :

( - )  
[ - - - ]

( )

أهم عمليات إدارة المعرفة

العمليات الفرعية	العمليات الأساسية	الكاتب
-	-	E.Turban
-	-	
-	-	
-	-	
-	-	
-	-	
-	-	
-	-	Laudon & Laudon
( KWS )	-	
-	-	
-	-	

( )

العمليات الفرعية	العمليات الأساسية	الكاتب
-	-	D. Skyrme
-	-	
-	-	
-	-	
-	-	
-	-	
-	-	
-	-	
-	-	
-	-	
-	-	
-	-	

العمليات الفرعية	العمليات الأساسية	الكاتب
-	-	
-	-	
/	-	
/	-	
-	-	
( ) /	-	
( ) /	( / )	
-	-	
-	-	
-	-	
-	-	

( )

- - - ]  
[..... - - - - -

( )

**( Knowledge Life Cycle )**

. ( )

**Knowledge )**

**( Proprietary**

( )

( ) : ( ) .

( )

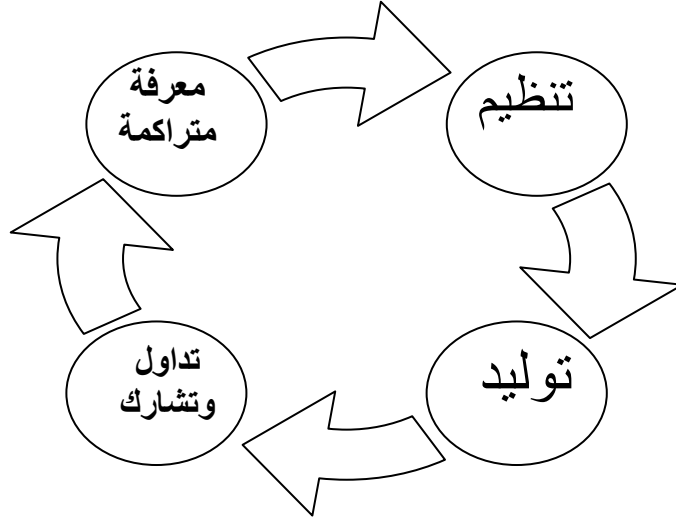

( )

( - - ) : .

### ١- تنظيم المعرفة

:

( )



: " .( )"

- ]

.[ -

{ DATA } ★

]

)["

.(

"

.( Wiig )"

"

**Prusak & Davenport )**

.(

)

.(

{ INFORMATION } : ★

)

(

( )

Prusak & Davenport

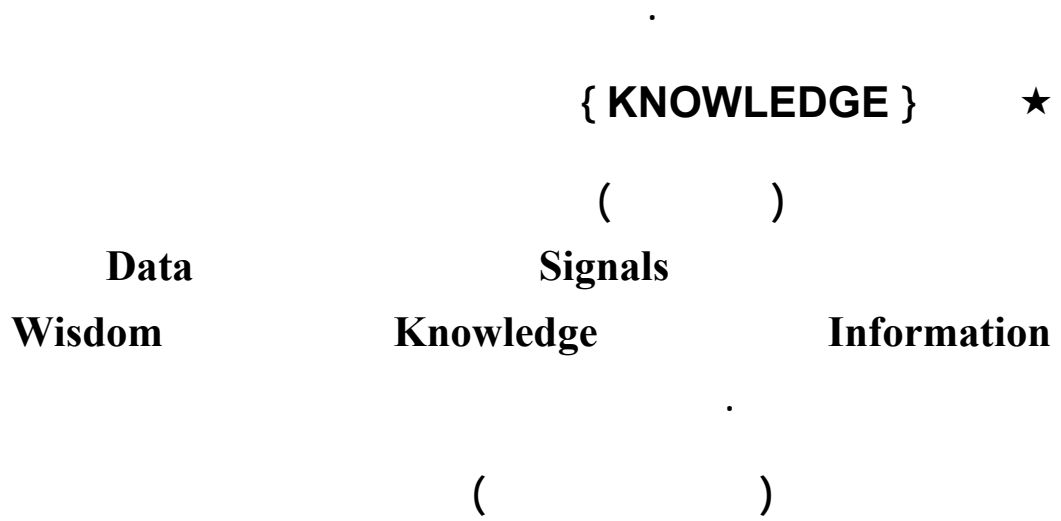

Warner & Norgan

) Know – How

( - )

( )

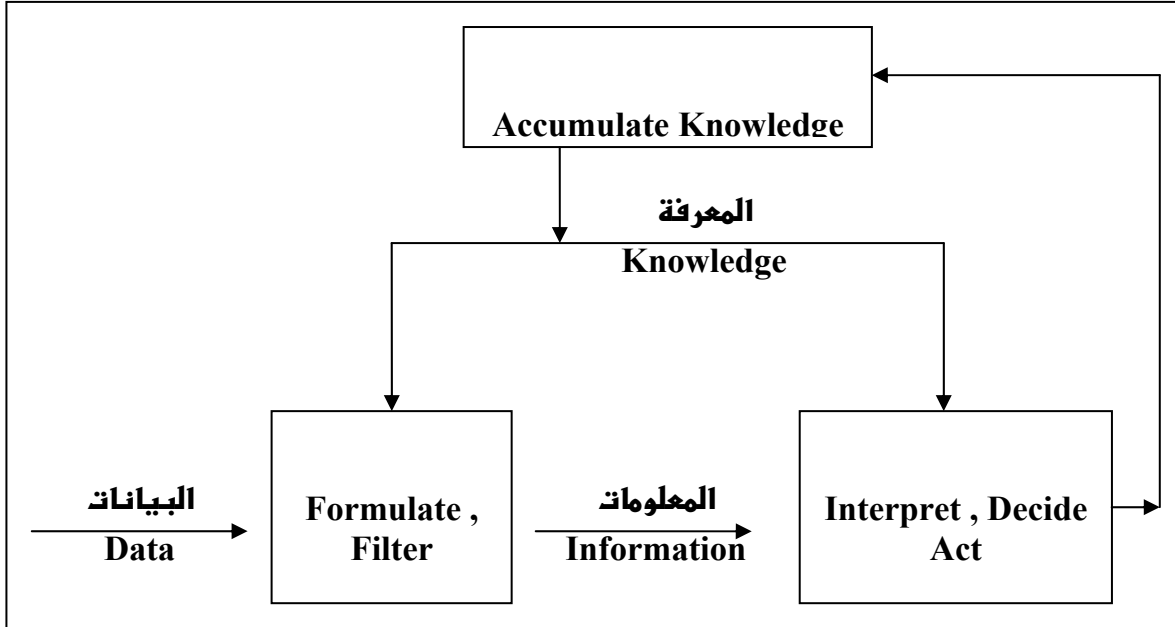

Source Alter Steve . Information systems : A management perspective . ( Reading Addision – wesely . 3th ed . 1999 - p . 49) .

٣- توليد المعرفة

:

( )

:( ) (

.

( )

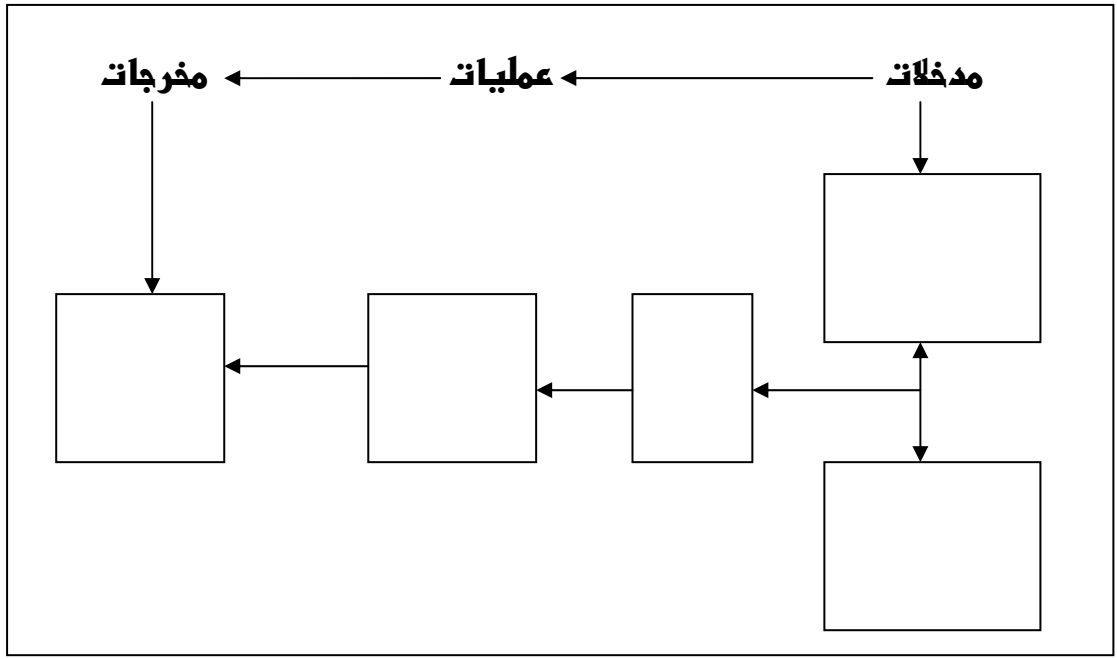

( )

) Witzel & Warner

( ) Wikham

( -

.

)

" "

" "

.( ) .(

( )

- ) Nonaka & Takeuchi

(

:

( )

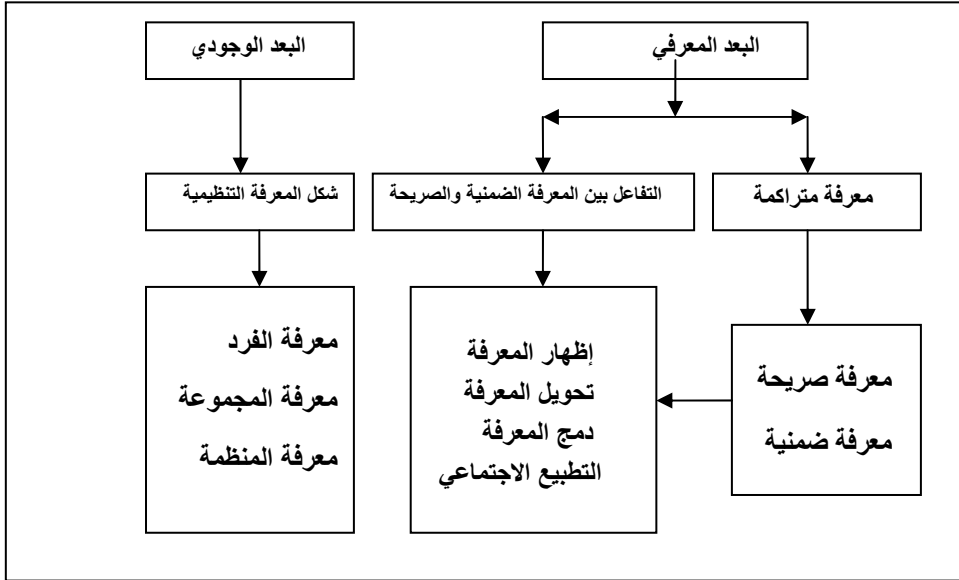

:

:

.

.

.

.

.

.

:

( - )

( )

: \_\_\_\_\_ :

:( **Socialization** )

:( **Externalization** )

:( **Combination** )

:( **Internalization** )

( )

( ) <b>Socialization</b>	( ) <b>Externalization</b>
<b>Internalization</b>	( ) <b>Combination</b>

: \_\_\_\_\_ (

: ( - )

- - - ]

: . [

( )

( )

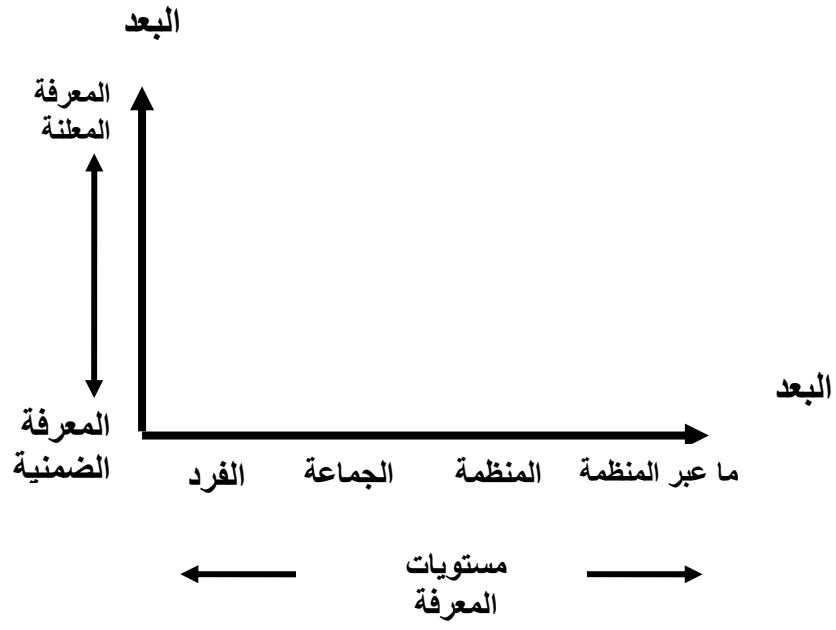

: \_\_\_\_\_ ( )

**Phatak & Bhagat** )

.( -

" ( )  
."

( - )

( )

:

( )

( )

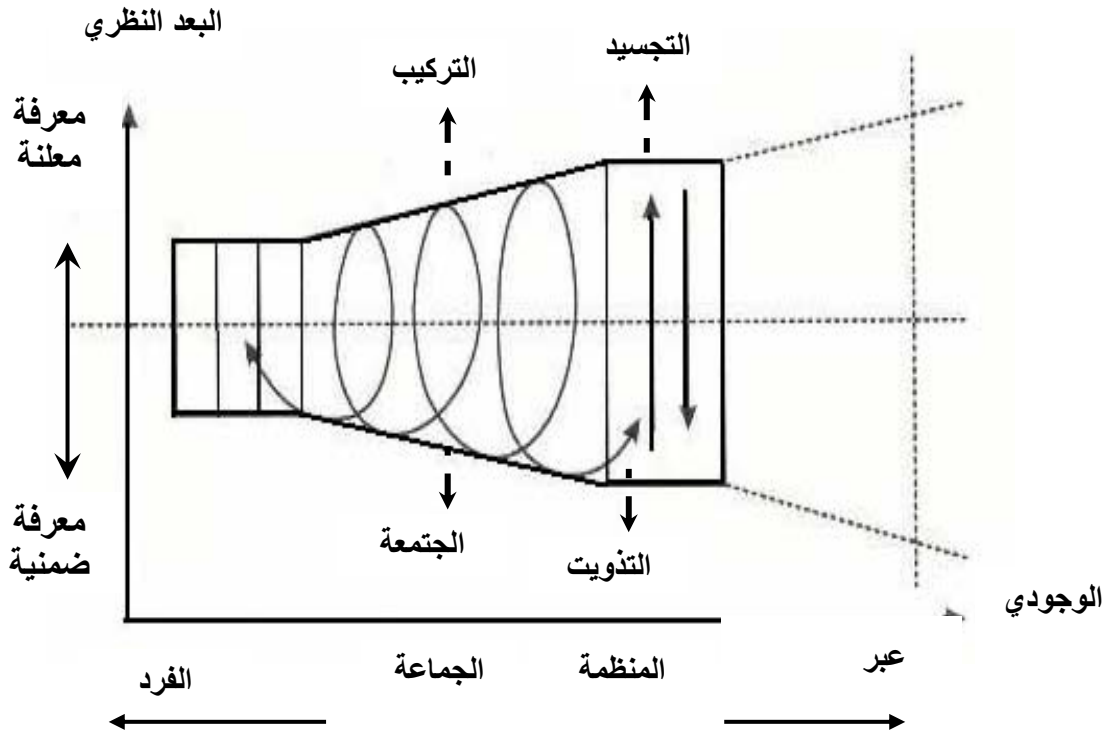

Inter –

Organizational Knowledge

Christina Ahmadjan

Creation : Knowledge and  
( ) Networks

Toyota

Silicon Valley

Saxenian

( )



### ٣- التشارك في المعرفة

.(( = ))  
.( )

( )

.( **Greengard** )  
**Marshal et.al** ).

.(

( - **Bhatt** )

( )

( ) Szulanski

( ) Coakes

**Knowledge Transfer**

" " " " " " " "

**Zmud**

.( **Zmud** )

( )

"  
.( **Morquandr** )"

\_\_\_\_\_  
:

.

\_\_\_\_\_  
:

.

## **الفصل الثالث**

### **إدارة المعرفة والجامعات المعاصرة**

- إدارة المعرفة والجامعات المعاصرة
- ممارسات إدارة المعرفة في الجامعات المعاصرة .
- إدارة المعرفة في جامعة أم القرى.

## الفصل الثالث

### إدارة المعرفة في الجامعات المعاصرة

تمهيد :

Wiig) .

.(

إدارة المعرفة والجامعات المعاصرة

( )

.( Daft )

knowledge Approach

Productivity

. Innovation

( )

Dubrin )

( -

## ممارسات إدارة المعرفة في الجامعات المعاصرة

( ) Nonaka & Takeuchi

:

-

....

-

( )

.

-

.

:

: \_\_\_\_\_ (

**& Takeuchi**

).

.(

**Nonaka**

:

:

•

(

**Wiig**)

:

.

○

.

○

.

○

○

.

( )

: •

( **Wiig** ).

:

o

o

o

o

: •

**Tece** )

( -

:

o

o

o

o

: •

- )

(

( )



.  
- )

.( - :

.  
.  
○  
○  
○

.  
:  
●

.  
.  
.  
.  
:  
○  
○  
○  
○

\_\_\_\_\_ (

)

.( **Nonaka & Takeuchi**

:  
:  
●

.( - Tece ).

:

.  
.  
.

o  
o  
o  
O

.

[ ]

:

•

:

.

o

.

.

o

.

o

o

.

:

•

.

:

.

o

o

.

o

o

.

( )

∴ ●

∴ ●

∴ ●  
○  
○  
○  
○

∴ ●

∴ ●  
○  
○  
○  
○

∴ ●  
●  
●  
●  
●

∴

:

(

(

(

(

(

(

(

(

(

(

:

(

(

(

(

(

(

(

(

(

( )

( )

.

(

:

.

(

.

(

.

(

.

(

.

(

.

(

.

(

.

(

.

(

.

(

:

.

(

.

(

.

(

.

(

.

(

.

(

(

.

(

.

(

.

(

( )

# إدارة المعرفة في جامعة أم القرى

## نبذة تاريخية :

/

/

.

.

//

.(

).

//

:

-

.

-

.

.

-

-

.

.

## ممارسات إدارة المعرفة في جامعة أم القرى

:

أولاً: الأداء الجامعي العام

:

" " (

(

.

(

.

.

.

(

.

(

.

.

.

.

.

( )



ثانياً : ممارسات وأنشطة منظمات الجامعة

: ( www.uqu.edu.sa )

: \_\_\_\_\_

:

:

:



)

.((

.

.

:

.

•

.

•

.

•

.

•

.

•

.

•

.

•

.

•

.

•

.

•

.

.

:

.

.

( )

⋮  
\_\_\_\_\_

...

•  
⋮  
\_\_\_\_\_

•

⋮ •

•

•

⋮  
\_\_\_\_\_

•

⋮

•

( )

.

.

:

:

---

.

.

.

## الفصل الرابع

### إجراءات الدراسة

- أهداف الدراسة الميدانية
- منهج الدراسة
- عينة الدراسة
- أداة الدراسة
  - تصميم الأداة
  - تقنين الأداة
- الأساليب الإحصائية المستخدمة

## الفصل الرابع

### إجراءات الدراسة الميدانية

#### تمهيد

#### أهداف الدراسة الميدانية

:

(

)

(

(

(

:

.

(

:

(

.

(

.

(

- ]

[

-

-

. [ - - ]

(

.

(

### منهج الدراسة

"

)"

.(

"

.( )"

"

( )

.( )"

**عينة الدراسة :**

- -

( )

**أداة الدراسة :**

)

(

:

**١- تصميم الاستبانة :**

:

:( )

( )

:

( )

( )

:

:

( )



$$\frac{\vdots}{\cdot \quad - \quad \vdots}$$

-

( )

$$\frac{\vdots}{- \quad \vdots}$$

-

$$\frac{\vdots}{( )}$$

$$\frac{\vdots}{- \quad \vdots}$$

-

( )

$$\frac{\vdots}{- \quad \vdots}$$

-

( )

٢- تقنين الاستبانة :

:

Validity ❖

:

Logical Validity (

.

.( )

(% )

: ( )

.( )

( )

:

.( )

( )

:

.

( )

:

.

( )

:

.( )

( )

.( )

( )

Content Validity : (

:

( )

تشارک	تولید	تنظیم	إدراک	المتغيرات
,	,	,	---	
,	,	--		
,	---			
---				

( )

: \_\_\_\_\_ ❖

(  $\alpha$  )

:

( )

معامل ( $\alpha$ )		المجال
أنثى	ذكر	
,	,	
,	,	
,	,	
,	,	
,	,	
,	,	
,		

( )

( )

٣- تطبيق الاستبانة :

( ) ( )  
 ( )  
 . ( )

وصف عينة الدراسة :

:  
 .  
 :

التكرارات والنسب المئوية		الفئات
%		
% ,		
% ,		
%		

( )  
 (% , ) ( )  
 .(% , ) ( )  
 ( )

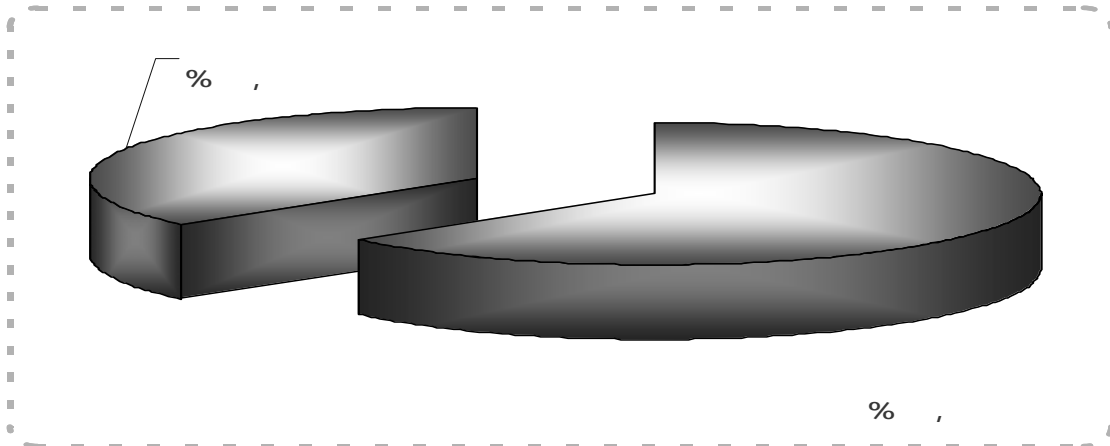

( )

( )

المجموع		أنثى		ذكر		الفئات
%		%		%		
% ,		,		% ,		
% ,		,		% ,		
% ,		,		% ,		
% ,		,		% ,		
% ,		,		% ,		
%		% ,		% ,		

( )

(% )

( )

(% , )

( )

(% , )

( )

( )

(% , )

( )

.(% )

( )

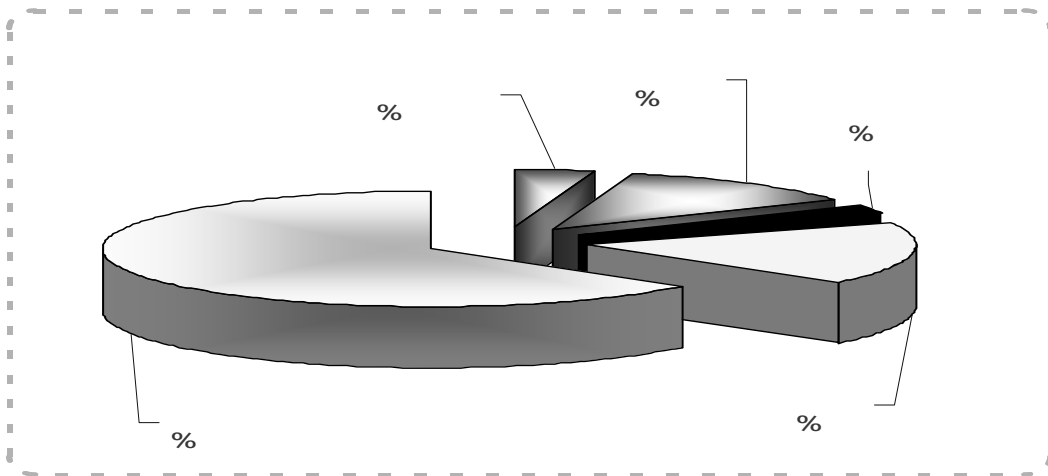

( )

( )

المجموع		أنثى		ذكر		الفئات
%		%		%		
% ,		,		,		
% ,		,		,		
% ,		,		,		
% ,		,		,		
%		% ,		% ,		

( )

( ) ( , %) ( )

( )

% ,

.% ,

( )

% ,

( )

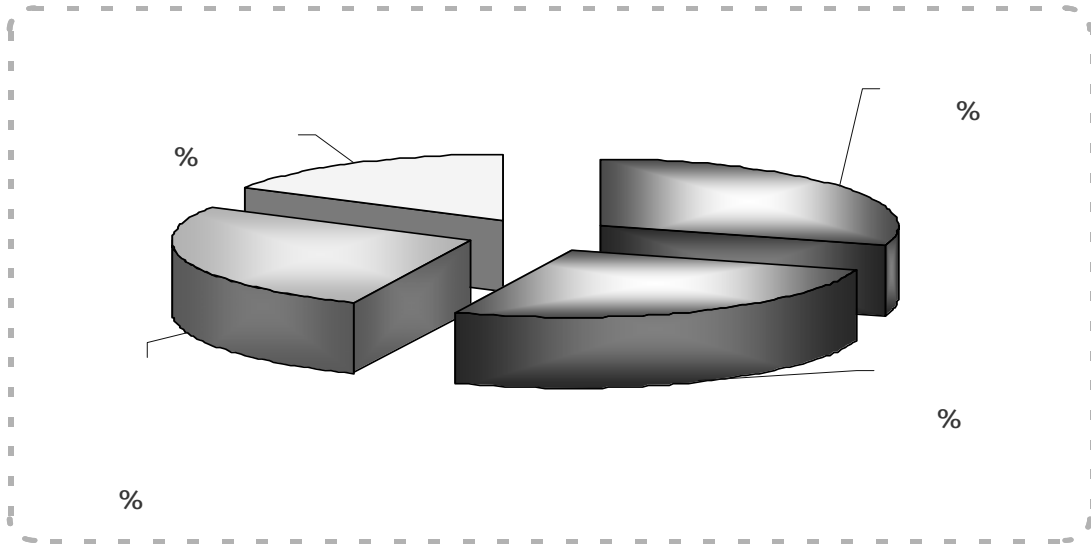

( )

( )

المجموع		أنثى		ذكر		الفئات
%		%		%		
% ,		-	-	,		
% ,		,		,		
% ,		-	-	,		
% ,		,		,		
% ,		,		,		
% ,		,		,		
% ,		,		,		
% ,		,		,		
%		,		,		

( )

(% , ) ( )

(% ) ( )

(% , ) ( )

(% , ) ( )

(% , ) ( )

( )

(% , )

( )

.(% , )

( )

( )

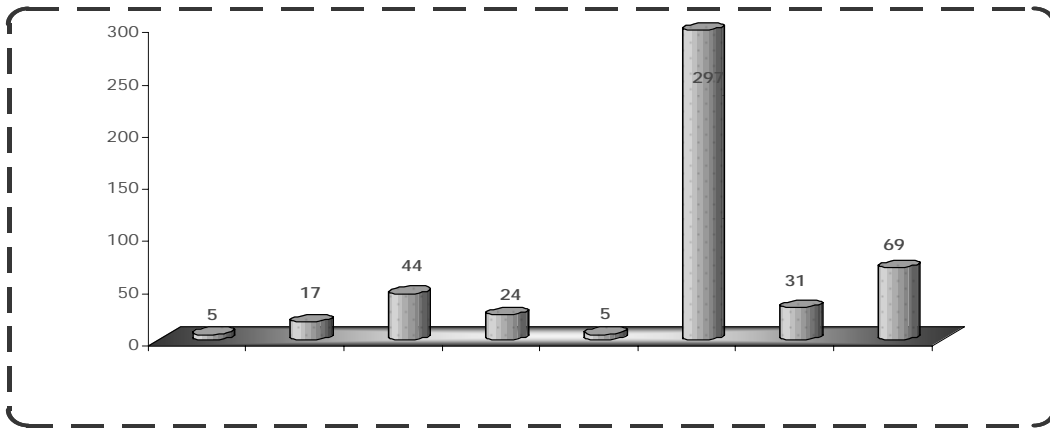

### الأساليب الإحصائية المستخدمة :

( SPSS )

:

.

.

.

.

( )

.

/ )

.(

.

:

( L.S.D )

.

( )

.

.

**Stepwise Multiple Regression**

.

( )



## الفصل الخامس

عرض نتائج الدراسة الميدانية تفسيرها

- الإجابة عن أسئلة الدراسة الميدانية وتحليلها .
  - إجابة السؤال الثالث .
  - إجابة السؤال الرابع .
  - إجابة السؤال الخامس .
  - إجابة السؤال السادس .
- مناقشة نتائج الدراسة الميدانية .

## الفصل الخامس

عرض نتائج الدراسة الميدانية وتفسيرها

تمهيد

( )

( - )

( - - - )

:

.( )

:

:

( )

أولاً : الإجابة عن أسئلة الدراسة الميدانية وتفسيرها :

( SPSS )

:

السؤال الثالث :

وللإجابة عن هذا السؤال:

-

:

$$+ [ \times ] + [ \times ] =$$
$$] + [ \times ]$$
$$[ \times ] + [ \times ]$$

$$\div =$$

$$\times =$$

( ) -

.

.

-

. %

. %

( )

( )

			%		%		%		%			
	/		/		/		/		/			
	/		/		/		/		/			
	/		/		/		/		/			
	/		/		/		/		/			
	/		/		/		/		/			
	/		/		/		/		/			
	/		/		/		/		/			
	/		/		/		/		/			
	/		/		/		/		/			
	/		/		/		/		/			
	/		/		/		/		/			
	/		/		/		/		/			
	/		/		/		/		/			
	/		/		/		/		/			
	/		/		/		/		/			
	/		/		/		/		/			
	/		/		/		/		/			
	/		/		/		/		/			

( )

( , - , )

( )

:

.

⋮  
\_\_\_\_\_

(

.( , )

(

.( , )

(

.( , )

.

⋮  
\_\_\_\_\_

(

.

.( , )

(

.

.( , )

(

.( , )

.

.

.

: ( )

( )

( )

		%		%		%		%		%		
'	'	'		'		'		'		'		.
'	'	'		'		'		'		'		.
'	'	'		'		'		'		'		.
'	'	'		'		'		'		'		.
'	'	'		'		'		'		'		.
'	'	'		'		'		'		'		.
'	'	'		'		'		'		'		.
'	'	'		'		'		'		'		.
'	'	'		'		'		'		'		.
'	'	'		'		'		'		'		.
'	'	'		'		'		'		'		.
'	'	'		'		'		'		'		.
'	'	'		'		'		'		'		.

( )

( )

( )

( , )

:

.

( )

(

.

( )

(

.

)

(

(

.

( )

(

.

**السؤال الرابع :**

)

(

**وللإجابة عن هذا السؤال :**

:

( )

( )

			%		%		%		%		
.	.	.	.	.	.	.	.	.	.	.	.
.	.	.	.	.	.	.	.	.	.	.	.
.	.	.	.	.	.	.	.	.	.	.	.
.	.	.	.	.	.	.	.	.	.	.	.
.	.	.	.	.	.	.	.	.	.	.	.
.	.	.	.	.	.	.	.	.	.	.	.
.	.	.	.	.	.	.	.	.	.	.	.
.	.	.	.	.	.	.	.	.	.	.	.
.	.	.	.	.	.	.	.	.	.	.	.
.	.	.	.	.	.	.	.	.	.	.	.
.	.	.	.	.	.	.	.	.	.	.	.
.	.	.	.	.	.	.	.	.	.	.	.
.	.	.	.	.	.	.	.	.	.	.	.
.	.	.	.	.	.	.	.	.	.	.	.
.	.	.	.	.	.	.	.	.	.	.	.
.	.	.	.	.	.	.	.	.	.	.	.

- , )

( )

: ( ,

( )



⋮  
\_\_\_\_\_ (

.( , )

(

.( , )

(

.( , )

⋮  
\_\_\_\_\_ (

.

.( , )

(

.

.( , )

(

.

.( , )

.

⋮ ( )

( )

( )

		%		%		%		%		%	
'	'	'		'		'		'		'	
'	'	'		'		'		'		'	
'	'	'		'		'		'		'	
'	'	'		'		'		'		'	
'	'	'		'		'		'		'	
'	'	'		'		'		'		'	
'	'	'		'		'		'		'	
'	'	'		'		'		'		'	
'	'	'		'		'		'		'	
'	'	'		'		'		'		'	
'	'	'		'		'		'		'	
'	'	'		'		'		'		'	

( , )

( )

( )

.( )

( )



- , )

( )

: .( ,

:

.

.

(

.( , )

.

(

)

(

.( , )

.

(

( , )

.

:

( )

( )

( )

		%		%		%		%		%	
'	'	'		'		'		'		'	
'	'	'		'		'		'		'	
'	'	'		'		'		'		'	
'	'	'		'		'		'		'	
'	'	'		'		'		'		'	
'	'	'		'		'		'		'	
'	'	'		'		'		'		'	
'	'	'		'		'		'		'	
'	'	'		'		'		'		'	
'	'	'		'		'		'		'	
'	'	'		'		'		'		'	
'	'	'		'		'		'		'	

( , )

( )

( )

.( )

( )

( )

			%		%		%		%		%		

( )

( , - , )

( )

:

.

:

\_\_\_\_\_

.

(

( , )

.

(

( , )

.

(

( , )

:

\_\_\_\_\_

.

(

.( , )

.

(

.( , )

.

(

.( , )

.

.

:

( )

( )

( )

		%		%		%		%		%	
'	'	'		'		'		'		'	
'	'	'		'		'		'		'	
'	'	'		'		'		'		'	
'	'	'		'		'		'		'	
'	'	'		'		'		'		'	
'	'	'		'		'		'		'	
'	'	'		'		'		'		'	
'	'	'		'		'		'		'	
'	'	'		'		'		'		'	
'	'	'		'		'		'		'	
'	'	'		'		'		'		'	
'	'	'		'		'		'		'	
'	'	'		'		'		'		'	
'	'	'		'		'		'		'	
'	'	'		'		'		'		'	
'	'	'		'		'		'		'	
'	'	'		'		'		'		'	
'	'	'		'		'		'		'	

( , )

( )

( )

.( )

( )



## السؤال الخامس

:

وللإجابة عن هذا السؤال :

( )

:

( )

( )

( / )

	( )				
,	-	,			
		,			
,	,	,			
		,			
,	,	,			
		,			
,	,	,			

( )

( / )

.( , )

( )

( )

	( )					
'	'	'		'		
		'		'		
		-		'		
'	'	'		'		
		'		'		
		-		'		
'	'	'		'		
		'		'		
		-		'		
'	'	'		'		
		'		'		
		-		'		

( )

. ( , )

: (L.S.D)

( )

( )  
( L.S.D )

( J - I ) =		(j)		(I)	
,	,		,		
,	,		,		
,	,		,		
,	,		,		
,	,		,		

) ( )  
( - )  
.( - -  
.  
( )

	( )					
,	,	,		,		
		,		,		
		-		,		
,	,	,		,		
		,		,		
		-		,		
,	,	,		,		
		,		,		
		-		,		
,	,	,		,		
		,		,		
		-		,		

( )

( )

. ( , )

: (L.S.D)

( )

( L.S.D)

( J - I)		(J)		(I)	
,	,		,	-	
,	,	-	,	-	
,	,		,		
,	,	-	,		
,	,		,	-	
,	,	-	,		
,	,		,		
,	,	-	,		
,	,		,	-	
,	,	-	,		
,	,		,		
,	,	-	,		
,			,	-	
,	,		,		

( )

)

. (

( )

( )

	( )					
'	'	'		'		
		'		'		
		-		'		
'	'	'		'		
		'		'		
		-		'		
'	'	'		'		
		'		'		
		-		'		
'	'	'		'		
		'		'		
		-		'		

( )

. ( , )

: (L.S.D)

( )

( )

( )

(L.S.D)

( J - I )		( J )		( I )	
,			,	...	
,			,		
,			,		
,			,		
,			,	...	
,			,	...	
,			,		
,			,		
,			,		
,			,	...	
,			,	...	
,			,		
,			,		
,			,		
,			,	...	
,			,		
,			,		
,			,		

( )

( )

.

( )

**السؤال السادس :**

( )

( )

**وللإجابة عن هذا السؤال استخدم الباحث أسلوب الانحدار الخطي :**

[ ] [ ] :

( )

( ) ( )

		T-- Test			F--- Test		R square	R	
	Beta						% ,	% ,	
,	,	,	,	,	,	,	% ,	% ,	

( )

( )

: ( )

(% , ) ( ) -

. ( )

( , ) (F--- Test) -

. ( )

( , ) (T—Test) -

( , )

: -

$$, + , =$$

\*

$$Z , + = :$$

( )

( , )

[ ] [ ] ( )

### Histogram

Dependent Variable: tanzemtot

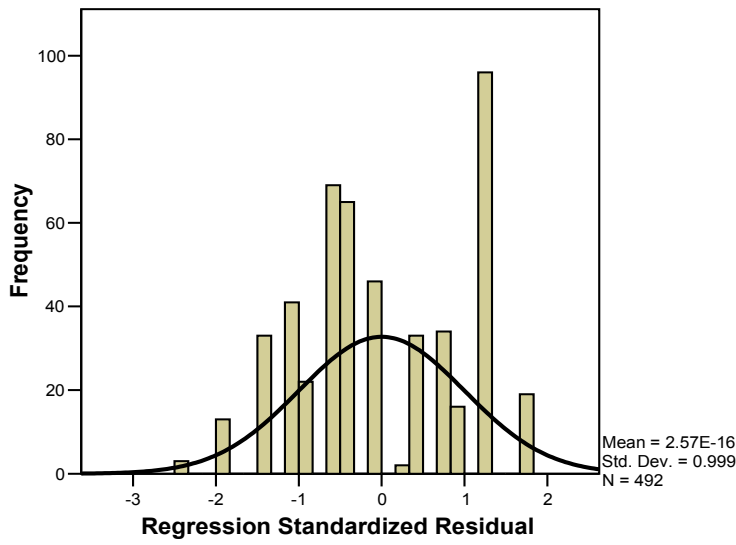

[ ] [ ] :

( )

( ) ( )

		T-- Test		F--- Test					
		Beta				R square	R		
,	,	,	,	,	,	% ,	%		

( )



( ) ( )

:

(% ) ( ) -

( , ) (F--- Test) -

( , ) (T—Test) -

:

, + , =

**Z** , + = :

( , )

[ ] [ ] ( )

**Histogram**

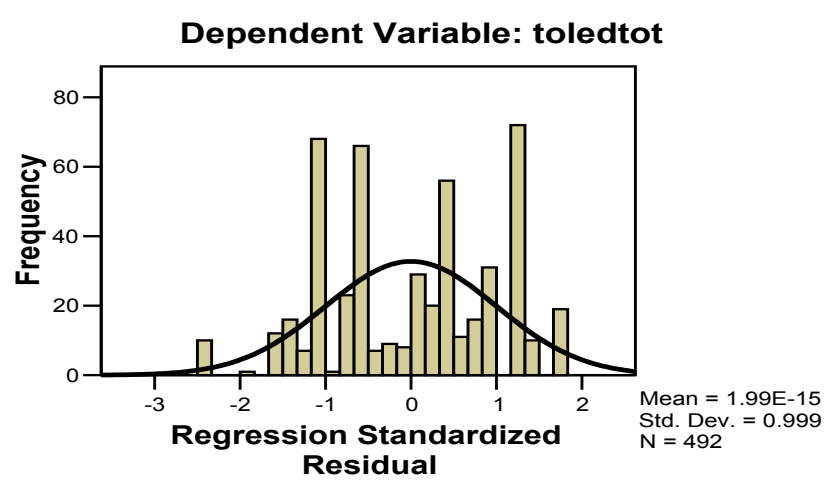

( )

[ ] [ ] :

( )

( ) ( )

		T-- Test		F--- Test				
		Beta				R square	R	
,	,	,	,	,	,	% ,	% ,	

( )

( )

: ( )

(% , ) ( ) -

. ( )

( , ) (F--- Test) -

. ( , )

( , ) (T—Test) -

( , )

: -

, + , =

\*

**Z** , + = :

( , )

.

( )

[ ] [ ] ( )

**Histogram**

**Dependent Variable: mosharkatot**

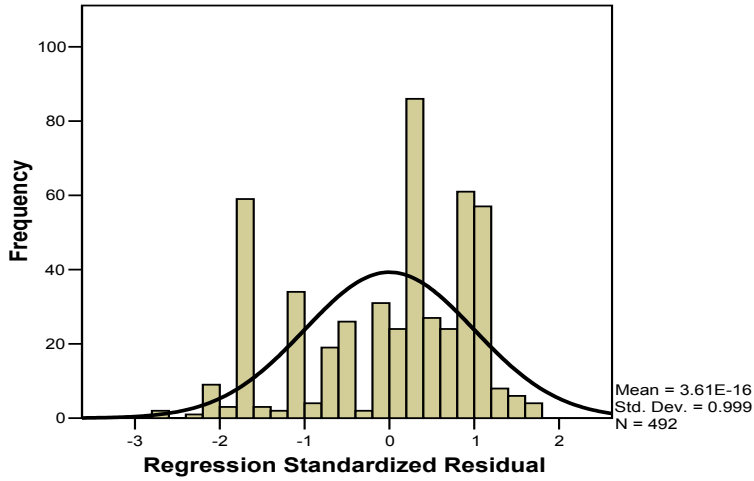

[ ] [ ] :

( )

( ) ( )

		T-- Test		F--- Test		R square		R	
		Beta							
,	,	,	,	,	,	,	% ,	% ,	

( )

( )

: ( )

(% , ) ( ) -

( )

( , ) (F--- Test) -

( , )

( )

( , ) (T—Test) -  
 ( , )

, + , = : -  
 \*

**Z** + = :

( , )

[ ] [ ] ( )

**Histogram**

**Dependent Variable: amaltot**

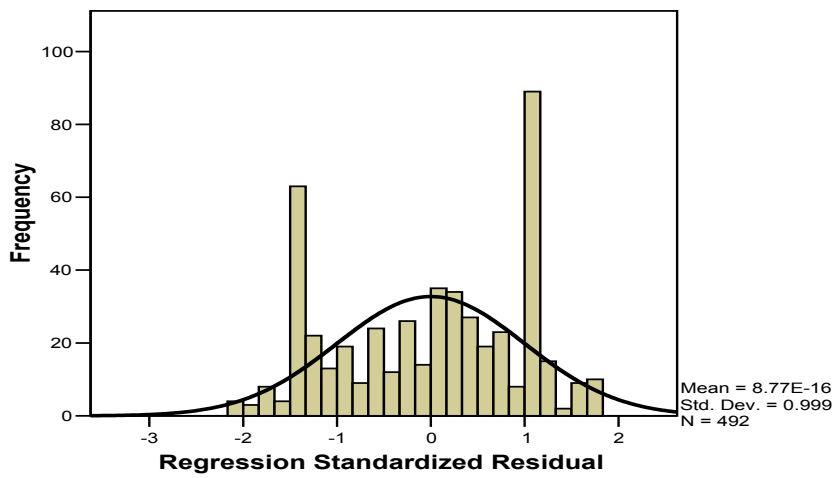

( )

( ) [ ] :

---

( )

( ) ( )

		T-- Test			F--- Test				
		Beta					R square	R	
,	,	,	,	,	,	,	% ,	% ,	

) ( )

:

(% , ) ( ) -

( )

.

( , ) (F--- Test) -

( , )

( , ) (T—Test) -

( , )

:

, + , =

\*

Z , + = :

( , )

.

( )

[ ] [ ] ( )

**Histogram**

**Dependent Variable: tanzemtot**

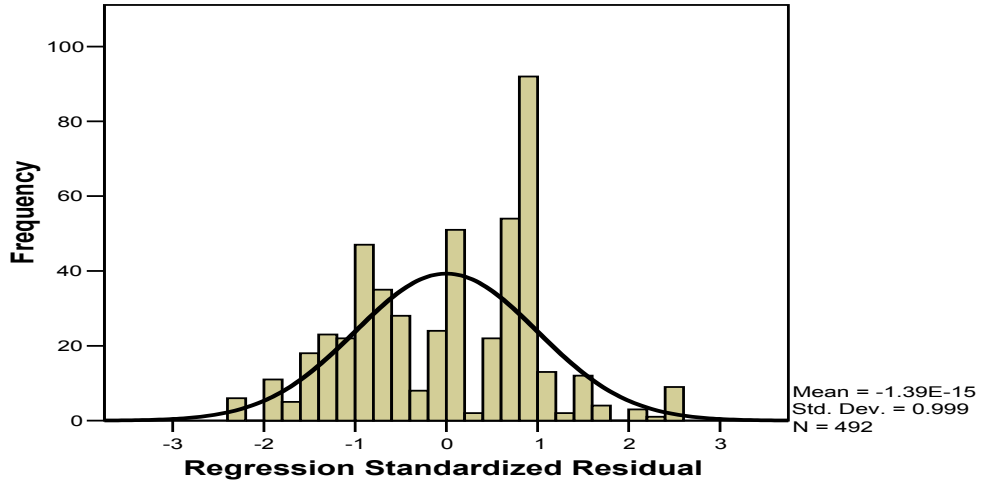

[ ] [ ] :

( )

( ) ( )

		T-- Test		F--- Test		R square		R	
Beta									
,	,	,	,	,	,	,	% ,	% ,	

) ( )

: ( ) (

(% , ) ( ) -

( )

( )

( , ) (F--- Test) -

( , )

( , ) (T—Test) -

( , )

: -

, + , =

\*

**Z** , + = :

( , )

.

[ ] [ ] ( )

### Histogram

Dependent Variable: toledtot

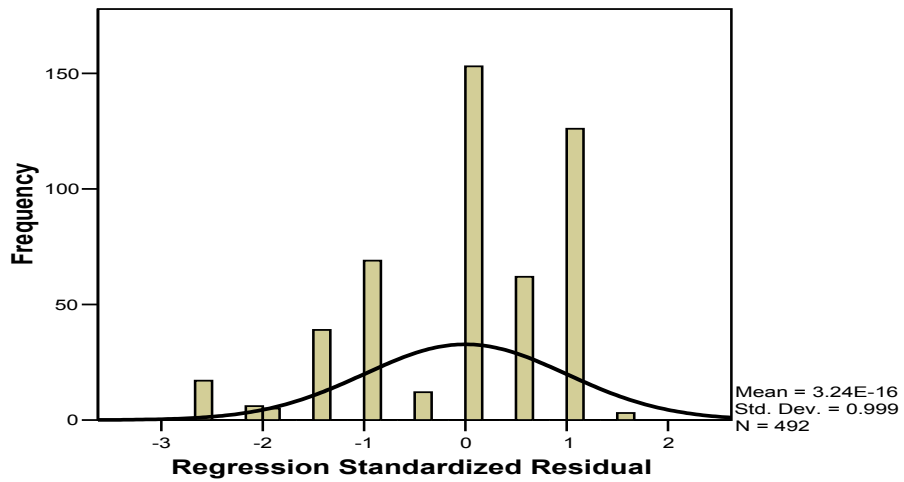

( )

[ ] [ ] :

( )

) ( )

(

		T-- Test			F--- Test				
		Beta					R square	R	
,	,	,	,	,	,	,	% ,	% ,	

) ( )

: ( ) (

(% , ) ( ) -

( )

.

( , ) (F--- Test) -

( , )

( , ) (T—Test) -

( , )

: -

, + , =

\*

Z , + = :

( )



( , )

[ ] [ ] ( )

Histogram

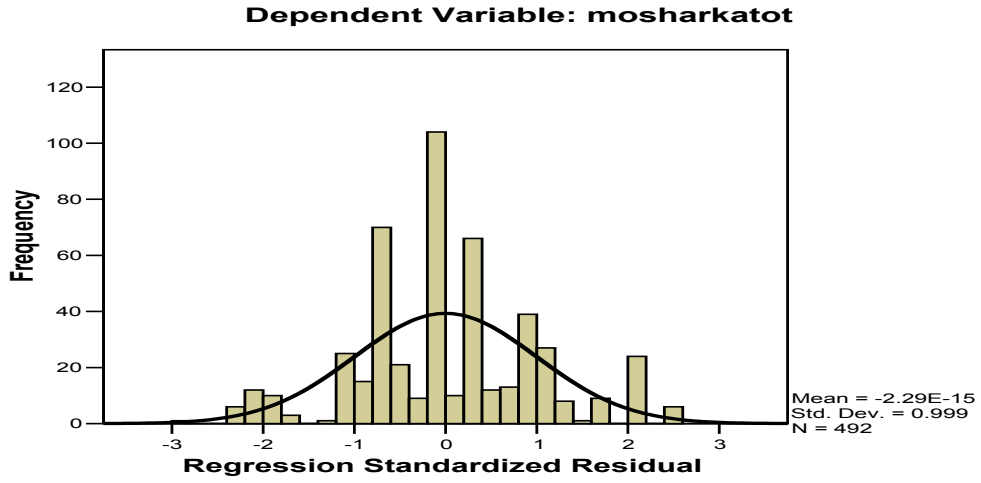

[ ] [ ] :

( )

) ( )

(

		T-- Test		F--- Test		R square	R
Beta							
,	,	,	,	,	,	% ,	% ,

)

( )

:

(

)

(

( )

(% , ) ( ) -  
 ( )

( , ) (F--- Test) -  
 ( , )

( , ) (T—Test) -  
 ( , )

, + , = :

\*

**Z** , + = :

( , )

[ ] [ ] ( )

**Histogram**

**Dependent Variable: amaltot**

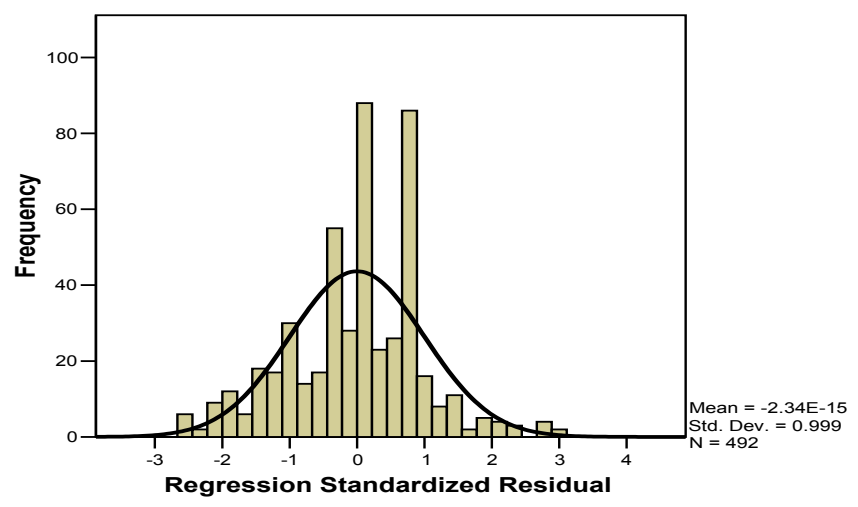

( )

$$\frac{(\quad)(\quad)}{(\quad)} :$$

$$)(\quad)$$

(

		T-- Test		F--- Test				
		Beta				R square	R	
	,	,		,				
	,	,		,			% ,	
	,	,		,				

( )

( )

: ( )

(% , )

-

( , )

(F--- Test)

-

( , )

( , )

(T—Test)

-

.( , )

( , )

$$, + , + , =$$

:

-

\*

$$Z , + Z , + =$$

:

( )

( , )

[

) (

)

( )

### Histogram

Dependent Variable: amaltot

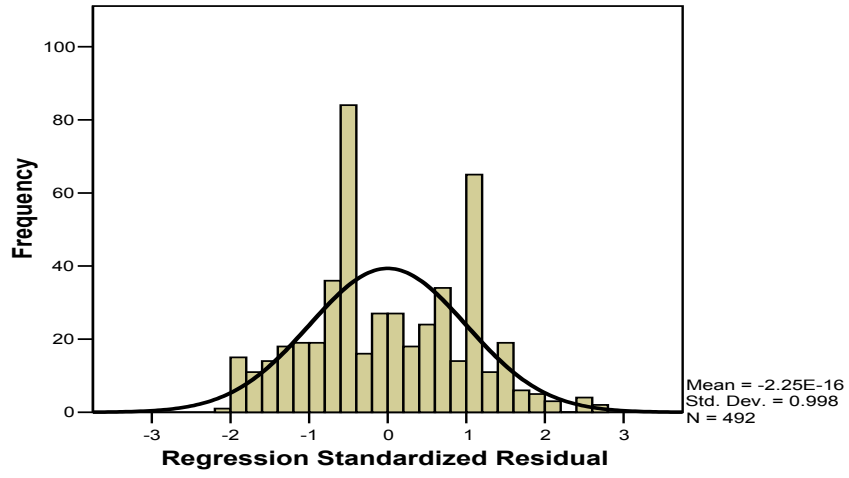

( )

## ثانياً : مناقشة نتائج الدراسة الميدانية

)

( -  
:

❖ مناقشة نتائج الدراسة المتعلقة بإدراك العاملين في جامعة أم القرى لمفهوم إدارة المعرفة وأهميتها وممارسة عملياتها.

:

(

( )

(

( )

" "

(

**Kylberg & Lundberg**

( )

(

( ) Carolyn

( )

(

( ) **Holowetzki**

- - - - )  
( -

(

( ) **Politis**

(

( ) **Connelly & Kellway**

(

( )

( ) Kylberg & Lundberg

(

❖ نتائج تتعلق بالمتغيرات الأولية لأفراد عينة الدراسة

:

-

Connelly & Kellway

-

( - )

-

( )

( )

)

( **Holowetzki**

.

-

.

( )



## **الفصل السادس**

التصور المقترح لإدارة المعرفة بالجامعات السعودية

**أولاً : ملخص نتائج الدراسة الميدانية**

**ثانياً : تصور مقترح لإدارة المعرفة بالجامعات السعودية**

- منطلقات التصور .
- أبعاد التصور .
- المقترحات وآليات تفعيل التصور .

## الفصل السادس

التصور المقترح لإدارة المعرفة بالجامعات السعودية

تمهيد

( - - ) .

أولاً : ملخص نتائج الدراسة الميدانية

:

:

(

.( , )

(

.( , )

(

.( , )

(

.( , )

(

.( , )

( )

		(
	.( , )	.
	.	(
		.( , )
		(
	.( , )	.
.		(
		.( , )
:		:
.		(
	.( , )	
	.	(
		.( , )
(		(
	.( , )	.
.		(
		.( , )
		(
	.( , )	
		(
		.( , )
.		(
	.( , )	
(		.
		(
		(
	( , )	
		(

. ( , ) (

:

:

. ( / ) (

(

( , ) .( - )

.

(

( , )

.

(

( , )

.

.

( )

## ثانيا : التصور المقترح لإدارة المعرفة بالجامعات السعودية

:

-

-

-

### ❖ منطلقات التصور المقترح

:

-

( - - )

- ]

[ -

-

-

-

-

-

:

-

•

•

.

•

.

•

.

### ❖ أبعاد التصور المقترح

-

: ( )

:

:

-

:

: ( ):

•

•

: ( ):

•

•

: ( ):

•

•

( )

:

( )

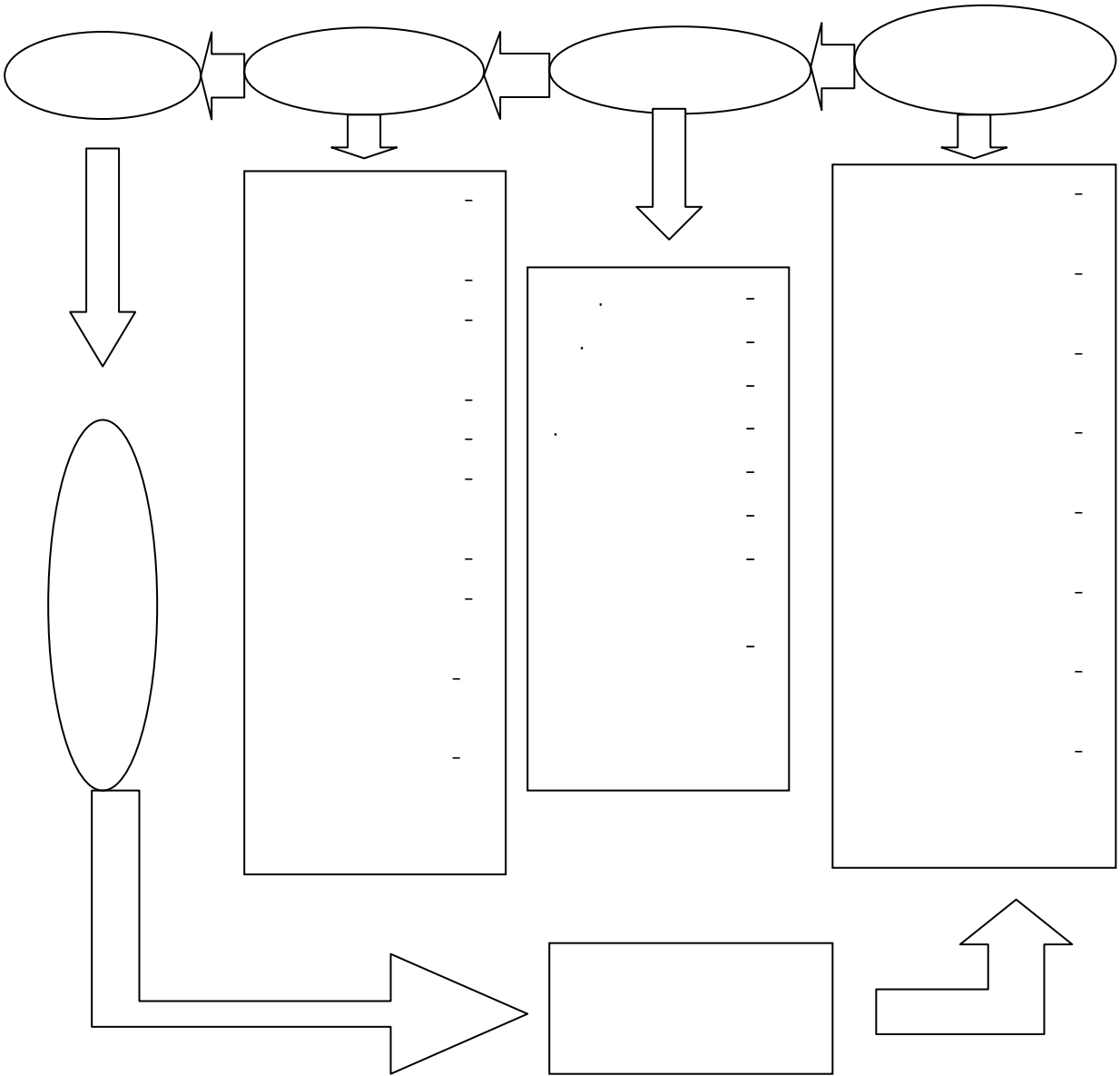

( )

:

:

.

.

:

:

.

●

●

●

.

.

:

.

:

.



## ثالثاً: التوصيات وآليات تفعيلها في الواقع الفعلي

:

.

:

:

.

•

•

.

•

.

•

.

:

.

:

.

•

.

•

.

•

.

•

.

:

:

.

•

.

•

•

.

•

.

•

.

:

:

●

.

●

.

●

.

●

.

●

.

●

.

:

.

:

.(

)

●

.

●

●

.

●

.

●

.

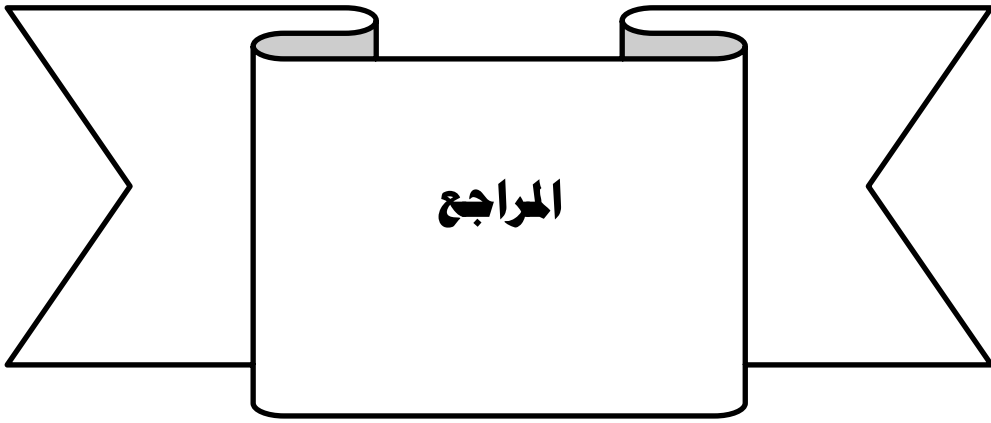

## المراجع العربية

\*

\_\_\_\_\_ : ( ) ( )  
)

· / / - ( )

· · : ( ) ( )

: ( ) - ( )

· : ( ) ( )

· · : ( ) ( )

· · : ( ) ( )

· · : ( ) ( )

· · : ( ) ( )

: ( ) ( )

· · : ( ) ( )

: ( ) ( )

: ( ) ( )

) :

· / / - ( )

· : ( ) ( )

· : ( ) ( )

- " "

·

· :( ) (

( ) :( ) (

·

· :( ) (

· :( ) (

· ( - ) ( ) ( )

· :( ) (

· :( ) (

( - )

· :( ) (

·

· :( ) (

( )

· :( ) (

· :( ) (

· :( ) (

·

· ( ) (

·

·

· :( ) (

·

· :( ) (

·

( ) (

( )

. . : ( ) (

:( ) (

"

"

. .

:( ) (

( ) .

-(

( ) (

:( ) (

:( ) (

:( ) (

: :( ) (

## المراجع الأجنبية :

- 1) Alter Steve . Information systems : A management perspective. (Reading Addison – wesely . 3th ed . 1999 - p . 49) .
- 2) Andrew.J.Dubrin,(2001) Leadership: Research Findings,Practice,and Skills (,New York Houghton Miffilm Company,pp380-387)
- 3) Balogun , J. and Hailey , V. P. ( 2004 ) Exploring Strategic Change, Harlow , England , Prentice Hall
- 4) Barnes , Stuart ( ed. ) ( 2002 ) Knowledge Management Systems: Theory and Practice , London , Thomson Learning
- 5) Bartlett ,C. A. , Ghoshal , S. and Birkinshaw , J. ( 2004 ) Transnational Management , Boston , McGraw Hill
- 6) Barton (2003): Core Capabilities and Core Rigidities : a Paradox in Managing New Product Development , Strategic Management Journal , No. ( 13 ) , pp 111 – 125 .
- 7) Capshaw , S. and Frappaolo , C. ( 1999 ) Knowledge Management Software : Capturing the Essence of Know – How and Innovation , The Information Management Journal , July , pp. 16 – 22
- 8) Carolyn , B (2001) Validating Aunified Framework For Knowledge Management .
- 9) Chan , Yolande and Ford , Dianne ( 2002 ) Knowledge Sharing in A Cross – Cultural Setting : A Case Study , Queen’s KBE Centre for Knowledge – Based Enterprises , [www.business.queensu.ca/kba](http://www.business.queensu.ca/kba) , Retrieved November 13 , 2003
- 10) Chauldhry ,A,Higgins ,S(2001) Perspectives on Eucation for Knowledge Management . 67 th if LA Council & General Conference .
- 11) Coakes , Elayne ( ed. ) ( 2003 ) knowledge Management : Current Issues and Challenges , U.S.A. , Idea Group Publishing
- 12) Coakes , Elayne ( ed. ) ( 2003 ) knowledge Management : Current Issues and Challenges , U.S.A. , Idea Group Publishing
- 13) Collins , Paul D. , Hage , Jerald , Hull , Frank and Teachman , Jay (1993) The Impact of Knowledge on the Survival of American Manufacturing Plants , Social Force , September 1993 , 72 ( 1 ) pp. 223 – 246
- 14) Connelly , Catherine E. and Kelloway , Kevin E. ( 2001 ) Predictors of Employees’ Perceptions of Knowledge Sharing Cultures , Queen’s Centre for Knowledge – Based Enterprises , [www.business.queensu.ca/kba](http://www.business.queensu.ca/kba) , Retrieved November 13 , 2003
- 15) Cullen , J. B. and Parboteeah K. P. ( 2005 ) Multinational Management.
- 16) Cummings , T. G. and Worley , C. G. ( 2005 ) Organization Development and Change , Australia , Thomson
- 17) Daft , R. L. ( 2001 ) Organization , Australia , Thomson
- 18) Daft , Richard and Noe , Raymond ( 2001 ) Organizational Behavior , U.S.A. , Horcourt College Publishers

- 19) Davenport , Thomas H. and Prusak , Laurence ( 2000 ) Working Knowledge : How Organizations Manage What They Know , Boston , Harvard Business School Press
- 20) David.J.Skryme (2001) : Capitalizing, Butterworth. Heinemann, oxford ,pp(5-6)
- 21) Denmis E.Winosky : KM ( 2001 ) : Approaches and Methodologies in : Roman C.Barquien et al ( Ed ) : Building Knowledge Management Environment For Electronic Government Concepts , Virginia , pp 16
- 22) Dubrin (2000 ) Fundamentals of Organizational Behavior, South-Westren,Australia
- 23) Efraim Turban.et al,(2002):Information Tecnology for Management,JohnWiley &Sons,Inc,New York .pp394-396
- 24) Fearnley , P. and Horder , M. ( 1997 ) What is Knowledge Management ? Knowledge Management in the Oil and Gas Industry , London Conference Proceedings Notes
- 25) Firestone , Joseph M. ( 2004 ) The Corporate Information or Knowledge Factory www.hpquire.com , Retrieved March 2 , 2004
- 26)Gartner Group ( 1998 ) 21st Century Vision , Information Strategy , 3 (9)
- 27) Greengard , s. ( 1998 ) Will Your Culture Support KM ? , Workforce , 77 ( 10 ) pp. 93 – 95
- 28) Griffiths , E. ( 1997 ) Knowledge Management for Global Operations and its Impact , Oil and Gas Industry , February 13 , pp. 61 – 70
- 29) Hailey , V. P. ( 2004 ) Exploring Strategic Change , Harlow , England , Prentice Hall
- 30) Holowetzki , Antonina ( 2002 ) The relationship Between knowledge Management and Organizational Culture : an Examination of Cultural Factors that Support the Flow and Management of Knowledge Within an Organization , Master Thesis , University of Oregon , U.S.A.
- 31) <http://www.alnoor-word.com/learn/topicbody.asp?TopicID=119&SectionID=1>
- 32) [http://www.kisr.edu.kw/webpages/km\\_newsletter/km-a-newsletter01.htm](http://www.kisr.edu.kw/webpages/km_newsletter/km-a-newsletter01.htm)
- 33) <http://www.uqu.edu.sa>.
- 34) Janzon , Hanna ( 2003 ) Management of Knowledge in Innovation : A Study of SKF Nova , Master Thesis , Gothenburge University
- 35) Kakes , Elayna , ed. ( 2003 ) Knowledge Management : Current Issue & Challenges , U.S.A. , Idea Group Publishing , p.74
- 36) Kang , T. ( 2003 ) The Knowledge Advantage : Tracing and Testing the Impact of Knowledge Characteristic and Relationship on Project Performance . PhD. Digital Dissertation University of California , Los Angeles , [wwwlib.umi.com / Dissertation / Search](http://wwwlib.umi.com / Dissertation / Search)



- 37) **Kylberg , Anna and Lundberg , Jenny ( 2002 ) Improving Knowledge Transfer : A Case Study of an Innovation Project at Tetra Pak , Master Thesis , Goteberg University**
- 38) **Kylberg , Anna and Lundberg , Jenny ( 2002 ) Improving Knowledge Transfer : A Case Study of an Innovation Project at Tetra Pak , Master Thesis , Goteberg University**
- 39) **Little , Stephen , Quintas , Paul and Ray , Tim (ed.) ( 2002 ) Managing Knowledge : An Essential Reader , London , Sage Publications**
- 40) **Malhorta , Y (1997) Knowledge Management in inquiring organization Brint institute on Knowledge .**
- 41) **Malhorta , Y (1998) Knowledge Management & ) Knowledge organization KM Workery aview from the front line Brint institute .**
- 42) **Marquardt , Michael J . ( 2002 ) Building the Learning Organization , U.S.,A. , Davis – Black publishing Company, p. 27**
- 43) **Marquardt , Michael J. ( 2002 ) Building the Learning Organization : Mastering the 5 Elements for Corporate Learning , U.S.A. , Davis – Black publishing Company**
- 44) **Marshall , C. , Prusak , L. and Shpilberg , D. ( 1996 ) Financial Risk and the Need for Superior Knowledge Management , California Management Review , 38 ( 3 ) pp. 77 – 101**
- 45) **Morris , A (2001) Knowledge Management : Apportuunity for List graduates 67 IF LA Council & General Conference .**
- 46) **Morten Hanson et al,(1999):Wats Your Strategy For Managing Knowledge ?,HABR, VOLL(77),No(2)Maech-April,pp106-116**
- 47) **Nguyen . Ted : “Knowledge Management “ SHRM 1998 .**
- 48) **Nonak , Ikujiro and Takeuchi , Hirotaka ( 1995 ) The Knowledge Creating Company : How Japanese Companies Create the Dynamics of Innovation , New York , Oxford university Press**
- 49) **Nonaka , Ikujiro ( 1998 ) The Knowledge – Creating Company , Harvard Business Review on Knowledge Management , U.S.A. , Harvard Business School Press**
- 50) **Nonaka , Ikujiro and Takeuchi , Hirotaka ( 1994 ) A Dynamic Theory of Organizational Creation , Organization Science , 5 ( 1 )**
- 51) **Nonaka , Ikujiro and Takeuchi , Hirotaka ( 2004 ) Hitotsubashi on Knowledge Management , Singapore , John Wiley & Sons ( Asia ) Pte Ltd.**
- 52) **Phatak , A. V. , Bhagat , R. S. and Kashlak , R. J. ( 2005 ) International Management , Boston , McGraw**
- 53) **Politis , John D. ( 2001 ) The relationship of Various Leadership Styles to Knowledge Management , Leadership & Organization Development Journal , 22 ( 8 ) pp. 354 – 364 , www.mcbup.com , Retrieved November 13 , 2003**
- 54) **Smith , Boyd K. ( 2004 ) The Socialization of Knowledge : A System View of Knowledge Management in Large , Complex , Highly Technical , Global Organizations , Fielding Graduate Institute , wwwlib.umi.com**

- 55) Stettner , Morey ( 2000 ) Skills for New Managers , U.S.A. , McGraw – Hill
- 56) Sveiby , K. ( 1997 ) The New Organizational Wealth : Managing and Measuring Knowledge Based Assets , Germany , Berrett – Koehler
- 57) Szualnski , G. ( 1996 ) Exploring Internal Stickiness : Impediments to the Transfer of Best Practice Within the Firm , Strategic Management Journal , 17 , pp. 27 – 43
- 58) T.Housel&A.H.Bell.cit,pp4-12
- 59) Tace , Strategies: For Managing Knowledge Asset the Role Firm Structure and Industrial Context , Long Range Planning, February 2000, vol(33)no.(1), pp35-54
- 60) Thornburg , David D (1997): 2020 Visions for The Future of Education. Thornburg Center .
- 61) Warner , M. and Witzel , M. ( 2004 ) Managing in Virtual Organizations , Australia , Thomson
- 62) Webster's Seventh New Collegiate Dictionary , G&C . Merram Company , Publishers , Springfield Massachusetts , U.S.A
- 63) Wickham , P. A. ( 2001 ) Strategic Entrepreneurship , Harlow , England Prentice Hall
- 64) Wiig , Karl M. ( 1994 ) Knowledge Management : the Central Management Focus for Intelligent Acting Organization , U.S.A. , Schema Press
- 65) Wiig , Karl M. ( 1993 ) Knowledge Management Foundations : Thinking About Thinking / How People and Organizations Create , Represent and Use Knowledge , U.S.A. , Schema Press
- 66) WWW .ICASit.org/km/kmrt/mayoz/index.htm .
- 67) Zerega , B. ( 1998 ) Art of Knowledge Management , Infoworld , July 27 , p. 61
- 68) Zmud , R. W. ( ed. ) ( 2000 ) Framing the Domain of IT Management : Projecting the Future Through the Past , Ohio , Pinnflex educational resources , Inc.

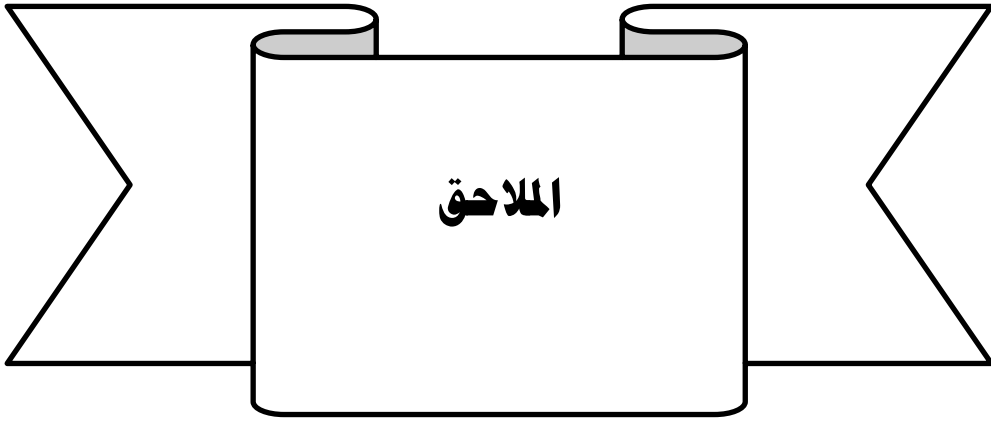

( )

( الاستبانة في صورتها الأولى )

-

( استبانة )

## إدارة المعرفة في الجامعات السعودية

دراسة تطبيقية على جامعة أم القرى

إعداد

ياسر عبدالله بن تركي العتيبي

إشراف

د/ رمضان أحمد عيد الصباغ

( )

/  
/

تحية طيبة،،

.

:

)

((.

:

.

:

.

.

.

.

:

:

:

:

:

:

:

.

.

.

الباحث

:

:

( )

## القسم الأول

### البيانات الشخصية :

الاسم : ..... ( اختياري )

الجنس :

.

.

المؤهل العلمي :

.

.

.

.

.

عدد سنوات الخدمة:

.

. -

. -

. -

العمل الحالي :

.

.

.

.

.

.

.

.....( )

## القسم الثاني

المحور الأول : إدراك مفهوم إدارة المعرفة وأهميتها :

			-		
			-		
			-		
			-		
			-		
			-		
			-		
			-		
			--		
			-		
			-		
			-		
			-		
			-		

**المحور الثاني : تنظيم المعرفة .**

			-		
			-		
			-		
			-		
			-		
			-		
			-		
			-		
			-		



**المحور الثالث : توليد المعرفة**

			-		
			( )		
			-		
			.		
			-		
			-		
			-		
			-		
			-		
			-		
			-		
			-		
			-		
			-		

### المحور الرابع :التشارك في المعرفة

			-		
			-		
			-		
			-		
			-		
			-		
			-		
			-		
			-		
			-		
			-		
			-		
			-		
			-		
			.		

( )

## بيان أسماء المحكمين

م	اسم المحكم	الجامعة	القسم
	.		
	.		
	.		
	.		
	.		
	.		
	..		
	.		
	.		
	.		
	.		

( )



( )

(الاستبانة في صورتها النهائية)

-

(استبانة)

## إدارة المعرفة في الجامعات السعودية

دراسة تطبيقية على جامعة أم القرى

إعداد

ياسر عبدالله بن تركي العتيبي

إشراف

د/ رمضان أحمد عيد الصباغ

( )

/  
/

### تحية طيبة..

.

(( : ))

:

:  
:

:

.

:  
:  
:  
:

-  
-  
-  
-

.

.

.

.

/ ❖

**الباحث**

:  
:

## القسم الأول

### البيانات الشخصية :

الاسم : ..... ( اختياري )

الجنس :

.

.

المؤهل العلمي :

.

.

.

.

.

عدد سنوات الخدمة:

.

. -

. -

. -

العمل الحالي :

.

.

.

.

.

.

.

.....( )

## القسم الثاني

المحور الأول : إدراك مفهوم إدارة المعرفة وأهميتها.

: .

						- ١
						- ٢
						- ٣
						- ٤
						- ٥
						- ٦
						- ٧
						- ٨
						- ٩
						- ١٠



المحور الثاني : تنظيم المعرفة .

: .

:

						-١
						-٢
						-٣
						-٤
						-٥
						-٦
						-٧
						-٨
						-٩
						-١٠

المحور الثالث : توليد المعرفة .

:

:

.

:

					) (	-١
						-٢
						-٣
						-٤
						-٥
						-٦
						-٧
						-٨
						-٩
						-١٠

المحور الرابع : التشارك في المعرفة

:

.

.

:

						-١
						-٢
						-٣
						-٤
						-٥
						-٦
						-٧
						-٨
						-٩
						-١٠